

Part of the Synthes Variable Angle Periarticular Plating System

# VA-LCP Proximal Tibial Plate 3.5

Surgical Technique



---

 Image intensifier control

This description alone does not provide sufficient background for direct use of DePuy Synthes products. Instruction by a surgeon experienced in handling these products is highly recommended.

**Processing, Reprocessing, Care and Maintenance**

For general guidelines, function control and dismantling of multi-part instruments, as well as processing guidelines for implants, please contact your local sales representative or refer to:

<http://emea.depuyshes.com/hcp/reprocessing-care-maintenance>

For general information about reprocessing, care and maintenance of Synthes reusable devices, instrument trays and cases, as well as processing of Synthes non-sterile implants, please consult the Important Information leaflet (SE\_023827) or refer to:

<http://emea.depuyshes.com/hcp/reprocessing-care-maintenance>

# Table of Contents

<b>Introduction</b>	VA-LCP Proximal Tibial Plate 3.5	2
	AO Principles	4
	Indications and Contraindications	5
<b>Surgical Technique</b>	Preparation	6
	Plate Insertion and Fixation	9
	Screw Insertion in the Plate Head	25
	• Insert VA locking screws Ø 3.5 mm in proximal row	25
	• Insert VA locking screws Ø 3.5 mm in second row	30
	Screw Insertion in the Plate Shaft	32
	• Insert cortex screws Ø 3.5 mm in plate shaft	32
	• Insert VA locking screws Ø 3.5 mm in plate shaft	38
	Screw Insertion in the Plate Neck	44
	Aiming arm removal	44
	• Insert VA locking screw Ø 3.5 mm in distal neck hole	46
	• Insert VA locking screw Ø 3.5 mm in proximal neck hole	48
Closure	50	
Implant Removal	51	
Care and Maintenance	53	
<b>Product Information</b>	Plates	54
	Screws	56
	Instruments	57
	Sets	65
<b>Bibliography</b>	Bibliography	68
<b>MRI Information</b>	MRI Information	69

# VA-LCP Proximal Tibial Plate 3.5.

## Part of the Synthes Variable Angle Periarticular Plating System.

The Variable Angle LCP Proximal Tibial Plate 3.5 is part of the VA-LCP Periarticular Plating System, which combines variable angle locking screw technology with conventional plating techniques.

### Variable angle (VA) locking technology

Four columns of threads in the VA locking holes provide a fixed-angle construct at the desired screw angle. VA locking holes allow +/- 15° off-axis screw angulation in order to:

Adapt screw trajectory to varying tibial plateau inclinations, thereby avoiding joint penetration

- Adapt screw trajectory to condyle size by distributing screws over the tibial plateau
- Capture fracture fragments and target specific anatomic regions
- Anchor screws in good quality bone
- Avoid collisions with other implants or prostheses

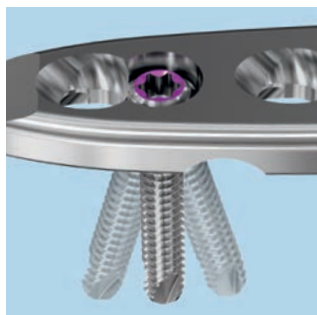

Color-coded VA locking screw heads for differentiation from locking screws



VA locking combi-holes in the plate shaft combine compression and VA locking capabilities

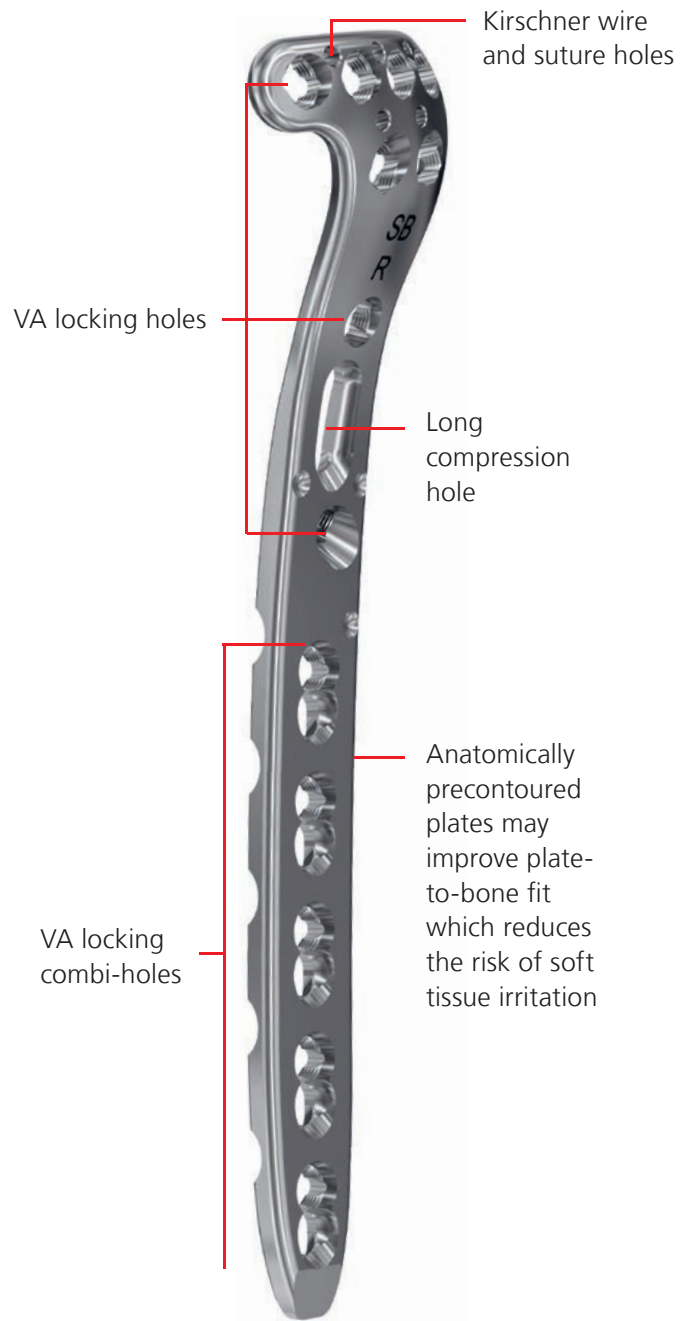

---

**Plates**

- Available in small and large bend to cover a wide range of tibial shapes
- Available in 4 to 14 holes ranging from 87 mm to 237 mm to cover both tibial plateau and associated metaphyseal and diaphyseal fractures

**Instrumentation**

- Instrumentation for straight forward assembly and improved handling
- Aiming arm for minimally-invasive screw insertion suitable for all plate types (right, left, small bend, large bend)
- Simple set configurations



# AO Principles

In 1958, the AO formulated four basic principles, which have become the guidelines for internal fixation<sup>1,2</sup>.

## **Anatomic reduction**

Fracture reduction and fixation to restore anatomical relationships.

## **Early, active mobilization**

Early and safe mobilization and rehabilitation of the injured part and the patient as a whole.

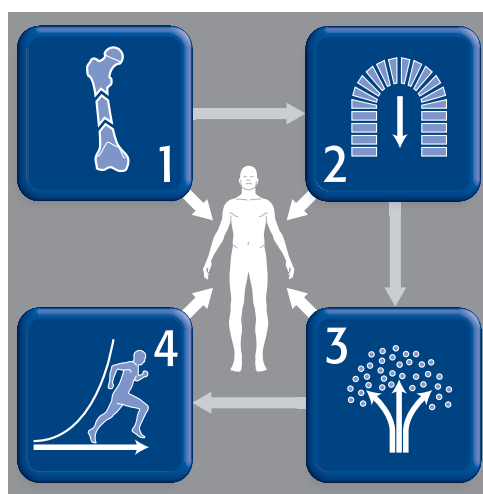

## **Stable fixation**

Fracture fixation providing absolute or relative stability, as required by the patient, the injury, and the personality of the fracture.

## **Preservation of blood supply**

Preservation of the blood supply to soft tissues and bone by gentle reduction techniques and careful handling.

<sup>1</sup> Müller ME, Allgöwer M, Schneider R, Willenegger H. Manual of Internal Fixation. 3<sup>rd</sup> ed. Berlin, Heidelberg, New York: Springer. 1991.

<sup>2</sup> Rüedi TP, Buckley RE, Moran CG. AO Principles of Fracture Management. 2<sup>nd</sup> ed. Stuttgart, New York: Thieme. 2007.

# Indications and Contraindications

## Indications

Fractures of the proximal tibia in adults and adolescents with closed growth plates including

- Proximal split, depression or split-depression fractures
- Bicondylar or pure metaphyseal fractures
- Associated metaphyseal or associated shaft fractures
- Periprosthetic fractures

## Contraindications

No specific contraindications.



# Preparation

---

## 1. Preparation

---

### Required sets

---

01.127.001	VA-LCP Proximal Tibial Plates 3.5, Stainless Steel
------------	---

---

01.127.003	VA Instruments and Long Screw Insertion Instruments 3.5
------------	--

---

01.127.004	Aiming Arm Instruments for VA-LCP Proximal Tibial Plates 3.5
------------	---

---

VA Locking Screws Ø 3.5 mm

---

### Optional sets

---

01.122.015	Screw Insertion Instruments 3.5/4.0, in Modular Tray, Vario Case System
------------	--

---

01.900.020	Extraction Set for Standard Screws Reduction Instruments
------------	---

---

Cortex Screws Ø 3.5 mm

---

- 1 Complete the preoperative radiographic assessment and prepare the preoperative plan.

Use the VA-LCP Proximal Tibial Plate 3.5 x-ray template (034.000.494 for right and 034.000.496 for left) for estimation of implant size.

**Note:** Preoperative planning of lag screws may be necessary.

**Note:** In case of (associated) shaft fractures, it is essential to insert four screws per fragment. Be sure to choose a plate of appropriate length to incorporate these screws.

**Note:** For information on fixation principles using conventional and locked plating techniques, please refer to the Synthes LCP Locking Compression Plate surgical technique: DSEM/TRM/0115/0278.

---

## 2. Patient positioning

Position the patient supine on a radiolucent operating table. The leg should be freely movable. The contralateral leg can be placed in an obstetric leg holder.

- Visualization of the proximal tibia under fluoroscopy in both the lateral and AP views is necessary.

Support the knee with towels to flex it into the appropriate position. Alternatively, the thigh can be placed and fixed in a leg holder in 50°–80° flexion.

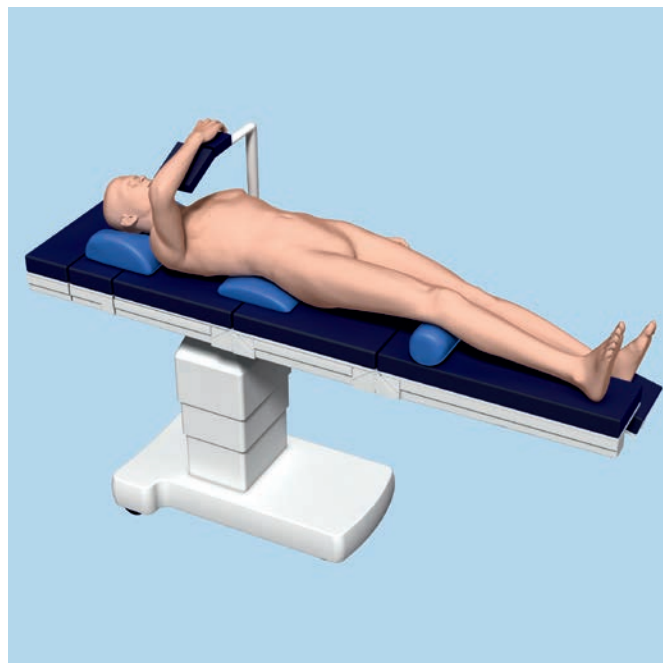

### 3. Surgical approach

Depending on requirements, perform either a curved (120° hockey stick) or a straight skin incision from Gerdy's tubercle about 50 mm in a distal direction.

Approximately half a centimeter from the tibial ridge, detach the anterior tibial muscle from the bone and retract it. The plate will be inserted in the space between the periosteum and the muscle. To allow correct positioning of the proximal part of the plate, it is important to adequately dissect the muscle attachment site.

For complex intra-articular fractures, an anterolateral arthrotomy that provides good control of the reduction may be preferred. The arthrotomy is performed underneath and parallel to the lateral meniscus. The meniscus is fixed and secured with resorbable retention stitches.

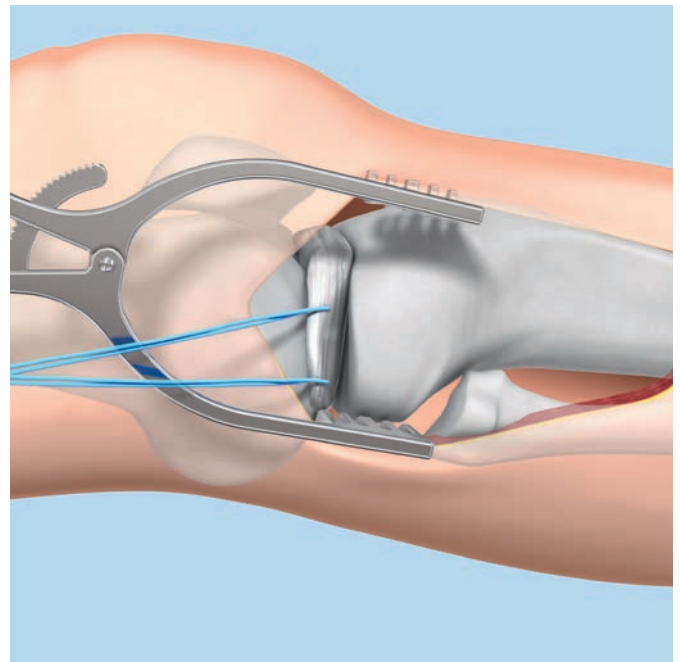
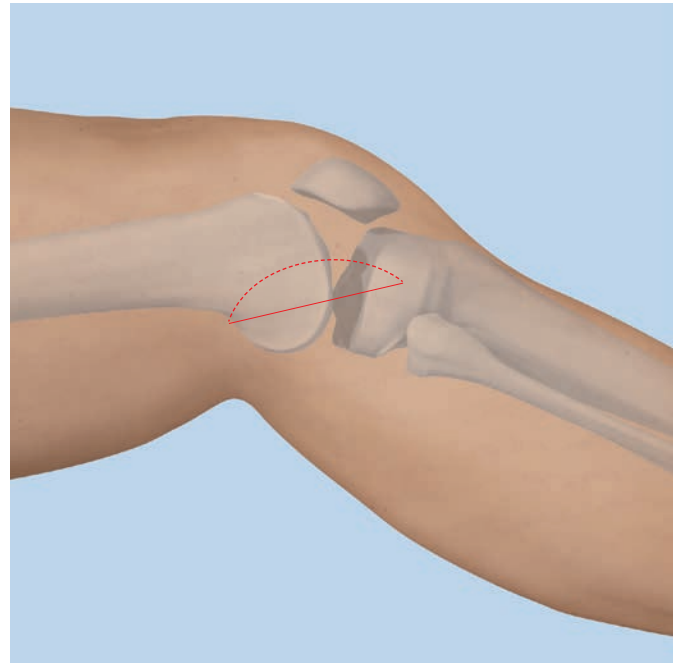

# Plate Insertion and Fixation

## 1. Determine plate type

### Instruments

03.127.012	Trial Implant for VA-LCP Proximal Tibial Plate 3.5, Small Bend, right, with 6 marked holes
03.127.013	Trial Implant for VA-LCP Proximal Tibial Plate 3.5, Small Bend, left, with 6 marked holes
03.127.014	Trial Implant for VA-LCP Proximal Tibial Plate 3.5, Large Bend, right, with 6 marked holes
03.127.015	Trial Implant for VA-LCP Proximal Tibial Plate 3.5, Large Bend, left, with 6 marked holes

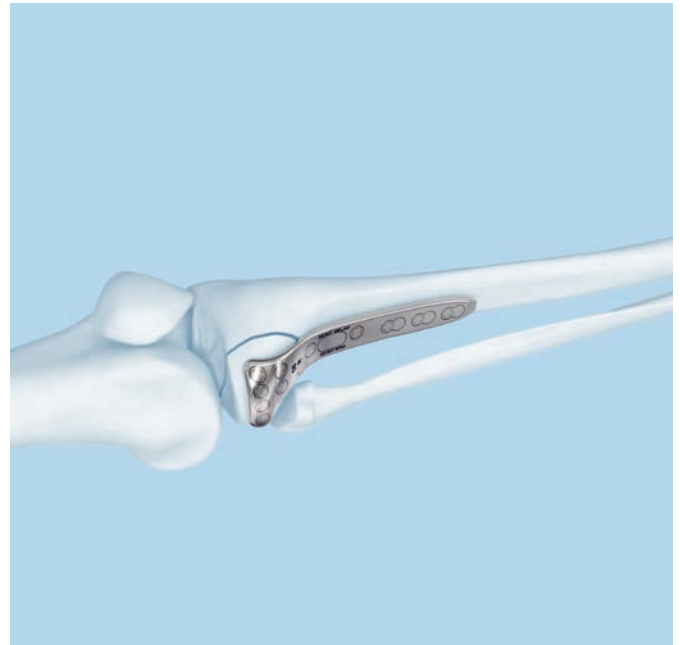

Use the trial implant for the correct side to determine the plate type (small bend/large bend) fitting best to the patient's anatomy. The trial implants are marked with "SB" and "LB" for differentiation.

**Note:** Take into consideration that the fractured bone might be broadened and lead to the identification of the wrong plate type. In this case, x-ray images of the other limb may be useful for comparison.

## 2. Prepare aiming arm instruments

### Instruments

03.124.004	Nut for Cannulated Interlocking Bolt
03.124.005	Cannulated Interlocking Bolt 1.6 mm or
03.124.006	Cannulated Interlocking Bolt 2.8 mm
03.127.007	Insertion Handle for Aiming Arm for VA-LCP Proximal Tibial Plate 3.5, right or
03.127.008	Insertion Handle for Aiming Arm for VA-LCP Proximal Tibial Plate 3.5, left
03.127.009	Aiming Arm for VA-LCP Proximal Tibial Plate 3.5
321.160	Combination Wrench Ø 11.0 mm

**Note:** In certain cases (e.g. proximal fracture treated with a short plate) it may be advantageous to do the surgery without using an aiming arm. Then for inserting VA locking screws in the plate shaft the same surgical technique as described in the section “Screw Insertion in the Plate Head” applies. Accordingly Cortex screws can be inserted in the shaft of the plate without using the aiming arm by applying the technique described in chapter 4 of the section “Plate Insertion and Fixation”.

Thread the nut onto a cannulated interlocking bolt. Choose between a bolt with cannulation 1.6 mm to insert a guide wire for preliminary fixation and a bolt with cannulation 2.8 mm to predrill the distal neck hole.



Choose the appropriate plate length, side and version (small/large bend) and place it on a flat surface to allow the correct assembly of the insertion handle and plate.

**Note:** The VA-LCP Proximal Tibial Plates are anatomically precontoured. Plate bending is not recommended. If the plate contour is changed, the aiming arm may not properly target the holes in the plate.

Position the insertion handle on the plate so that the pins on the underside of the insertion handle align with the three dimples around the distal neck hole. The flats on the side of the insertion handle help to mount the insertion handle in the correct orientation.



Insert the assembled interlocking bolt with nut into the insertion handle and thread it into the plate until tight. If the Allen key is used to tighten the bolt, make sure not to damage the hole. Tighten the nut with the combination wrench.



Thread the connection screw into the correct side of the aiming arm and attach the aiming arm to the insertion handle. Use the combination wrench to secure the connection screw and aiming arm to the insertion handle.

**Note:** The aiming arm can be used for all plate types (left, right, small bend, large bend). Be sure to attach the aiming arm in the correct orientation by checking the marked side on the top and side part of the aiming arm.

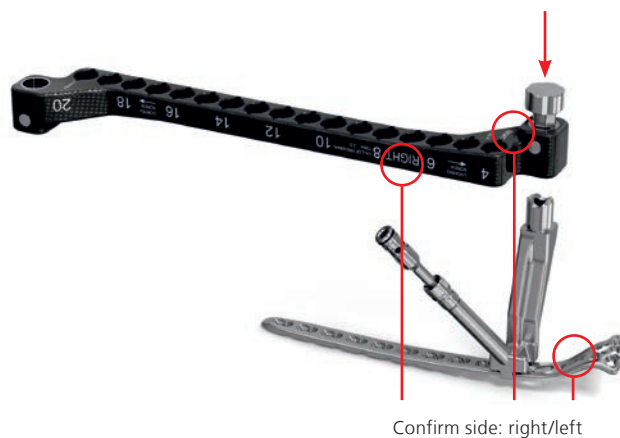

### 3. Insert and preliminarily fix plate

#### Instruments

292.200.01	Kirschner Wire Ø 2.0 mm with trocar tip, length 150 mm, Stainless Steel
323.360	Universal Drill Guide 3.5
03.113.023	Drill Bit Ø 2.5 mm with Stop, calibrated, length 250/225 mm, for Quick Coupling
319.090	Depth Gauge for Long Screws Ø 3.5 mm, measuring range up to 110 mm
314.550	Screwdriver Shaft, hexagonal, small, Ø 2.5 mm, length 165 mm, for Quick Coupling
03.019.005	Handle with Quick Coupling, length 150 mm

Using the aiming arm assembly, insert the plate between the anterior tibial muscle and the periosteum. Slide the plate in the distal direction with its distal end in constant contact with the bone. Carefully find the correct position of the plate on the condyle and the correct position of the distal part of the plate, either with an image intensifier or by direct palpation.

**Note:** The aiming arm can be attached either before or after insertion of the plate.

#### Precautions:

- Instruments and screws may have sharp edges or moving joints that may pinch or tear user's glove or skin.
- Handle devices with care and dispose worn bone cutting instruments in an approved sharps container.

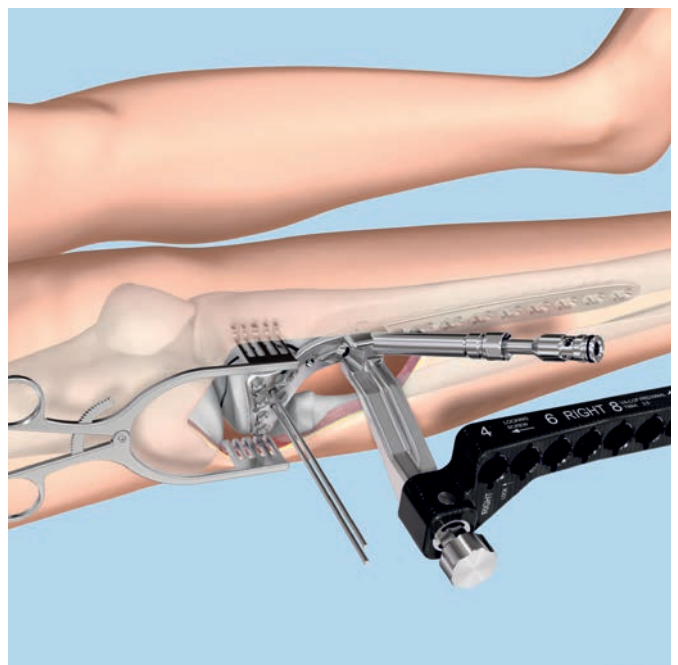
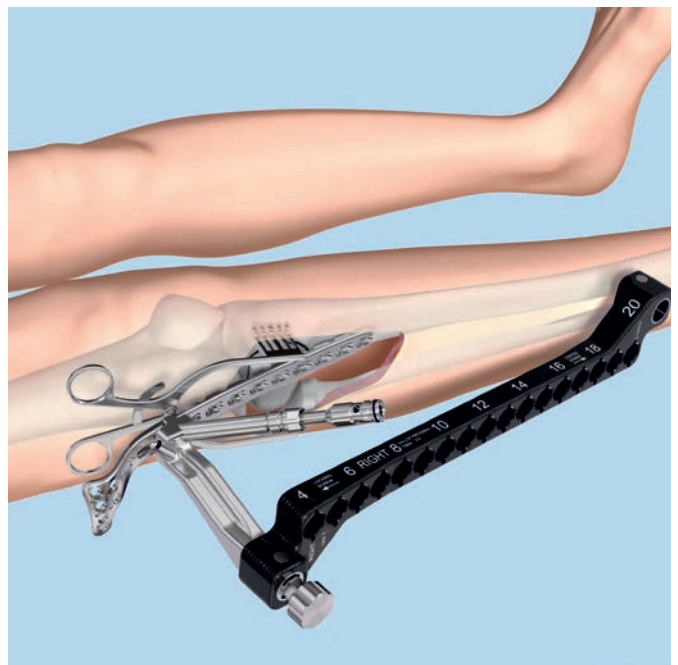

Insert Kirschner wires  $\varnothing$  2.0 mm through the Kirschner wire holes either in the proximal or in the middle part of the plate head to fix the plate to the bone.

Preliminarily secure the plate with a cortex screw through the long hole in the neck of the plate. Insert the drill bit  $\varnothing$  2.5 mm into the universal drill guide and advance it until it reaches the medial cortex.

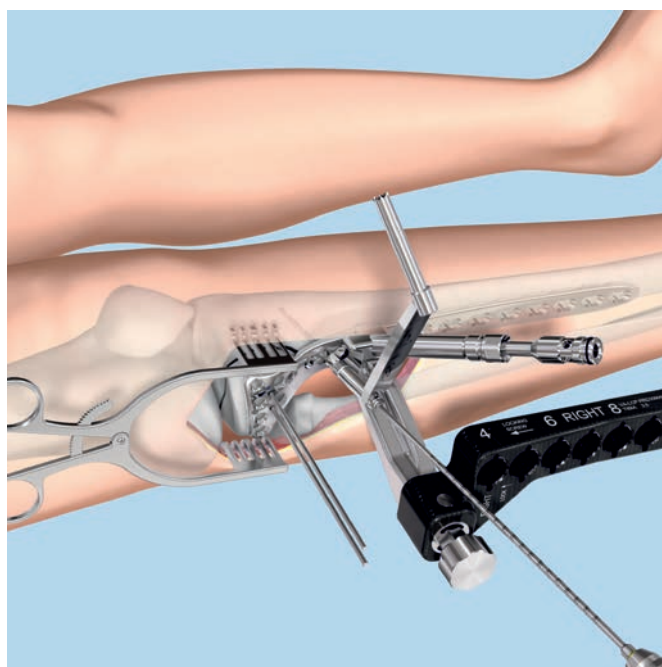
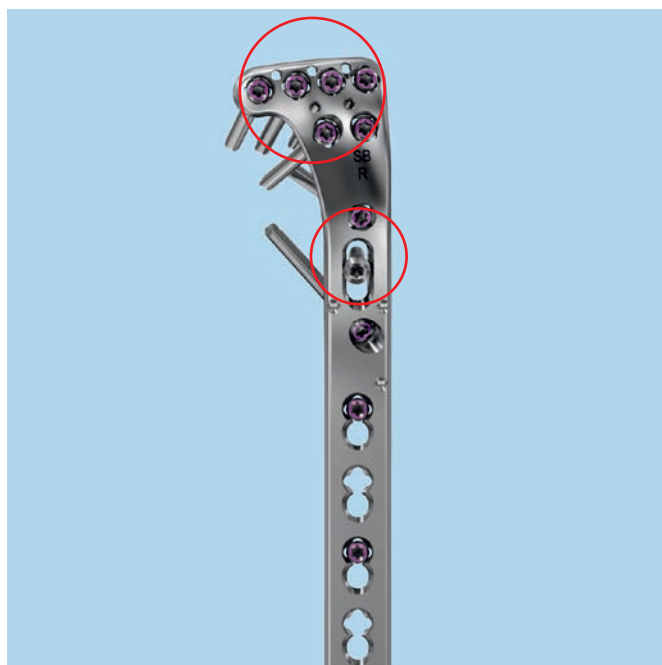

Remove the drill bit and drill guide and use the depth gauge to measure for screw length.

**Note: Do not use the drill bit calibration for screw measurement.**

---

### Optional instruments

---

311.310	Tap for Cortex Screws $\varnothing$ 3.5 mm, calibrated, length 175 mm
---------	---

---

03.019.005	Handle with Quick Coupling, length 150 mm
------------	---

---

For non-self-tapping cortex screws connect the long tap to the handle and tap the thread.

Insert the correct length cortex screw with the power tool using the hexagonal screwdriver shaft. For final tightening, assemble the screwdriver shaft to the handle and tighten the screw.

The long hole can assist in reducing lateral split fractures: tightening the cortex screw in the plate will compress the fragment to the bone (buttressing effect).

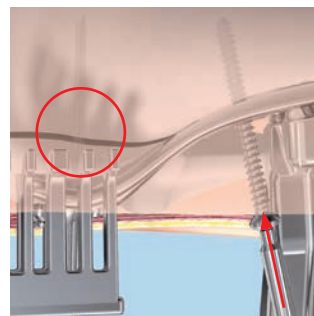
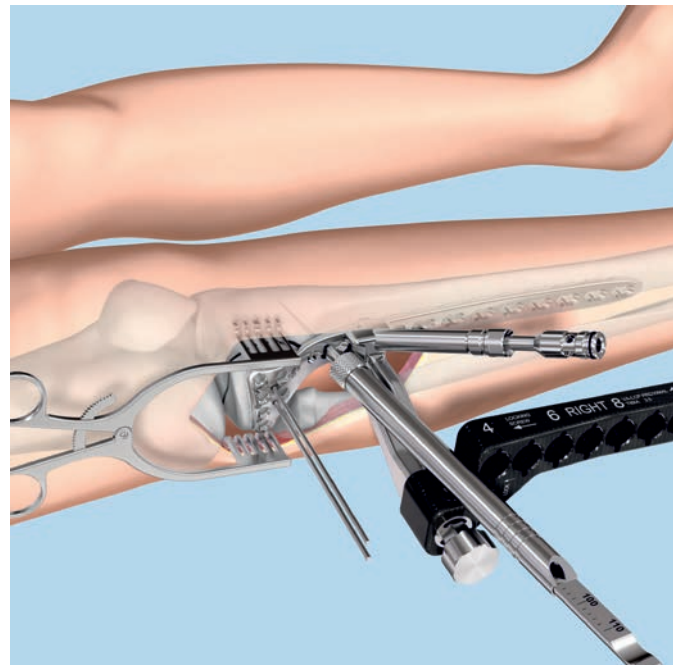

Tighten screw

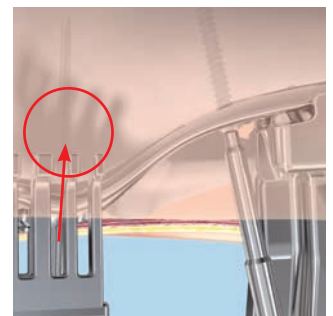

Fracture gap closes

**Note:** To avoid screw collision of the cortex screw in the long hole and the locking screw in the distal neck hole, insert a long drill guide to check the trajectory. When using an aiming arm, a Kirschner wire  $\varnothing$  1.6 mm can be inserted through the insertion handle.

At this point in time adaptations of the plate position can still be done.

**Precaution:** Proper plate position is key to success: a plate positioned too distally does not provide adequate rafting support of the articular surface; a plate positioned too proximally may damage the joint area with the proximal screws.

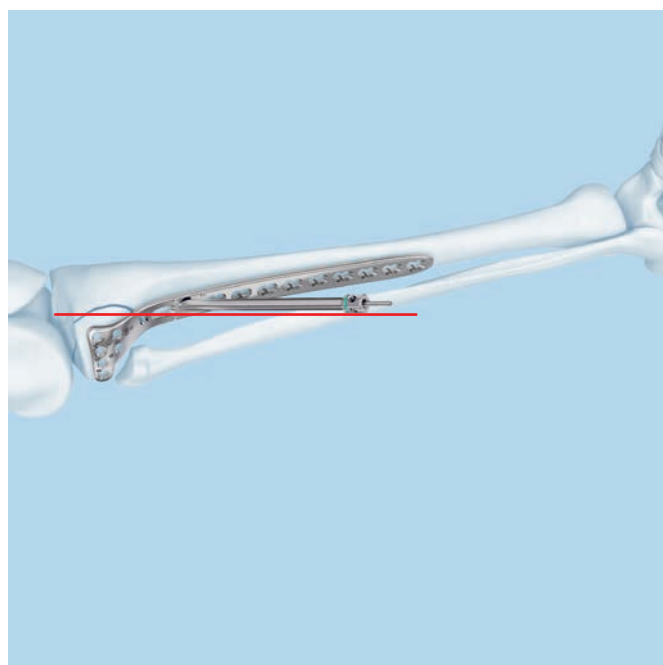
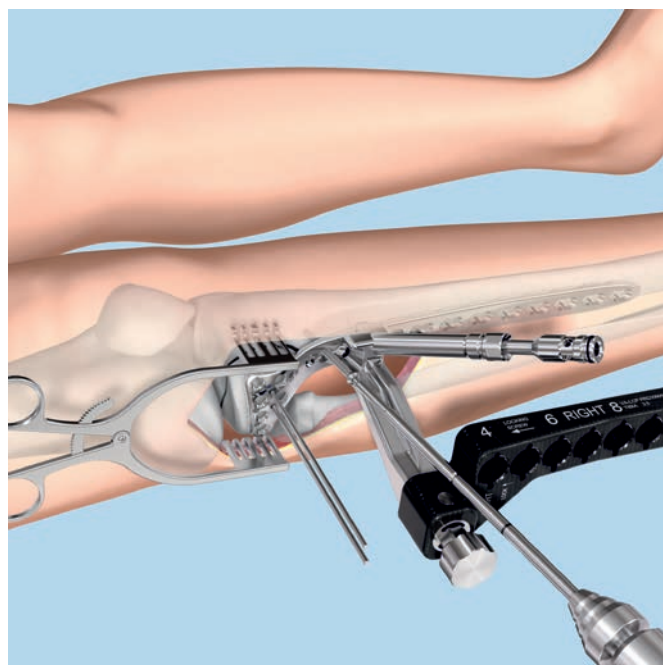

## 4. Reduce articular surface

### Instruments

323.360	Universal Drill Guide 3.5
03.113.023	Drill Bit $\varnothing$ 2.5 mm with Stop, calibrated, length 250/225 mm, for Quick Coupling
319.090	Depth Gauge for Long Screws $\varnothing$ 3.5 mm, measuring range up to 110 mm
314.550	Screwdriver Shaft, hexagonal, small, $\varnothing$ 2.5 mm, length 165 mm, for Quick Coupling
03.019.005	Handle with Quick Coupling, length 150 mm

Fracture reduction is usually done over the plate as the space for independent screws in the tibial condyle is usually restricted. However, fracture reduction can also be achieved by inserting independent compression screws in the zone proximal to the plate. Make sure that these screws neither collide with the locking screws of the plate nor penetrate the joint area.

In case of a split fracture, the lateral condyle has to be compressed with an interfragmentary cortex screw to fix the previously secured fragment.

**Note:** Make sure to insert enough VA locking screws to guarantee full construct stability.

Insert the drill bit  $\varnothing$  2.5 mm into the universal drill guide and advance it until it slightly penetrates the medial cortex.

Remove the drill bit and drill guide and use the depth gauge to measure for screw length.

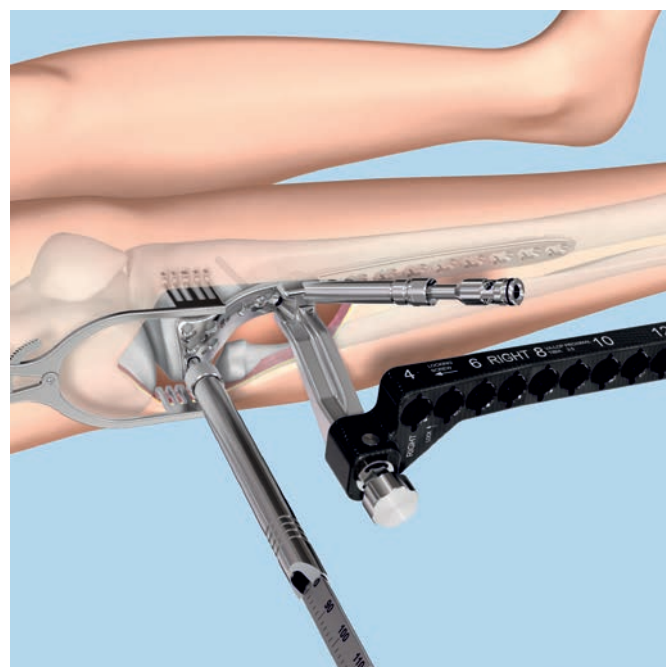
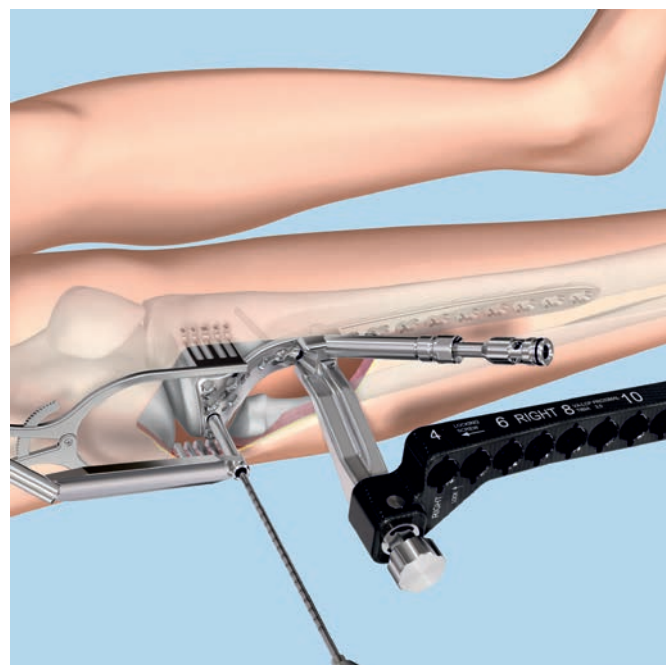

---

**Optional instrument**

---

311.310 Tap for Cortex Screws Ø 3.5 mm, calibrated, length 175 mm

---

For non-self-tapping cortex screws, use the long tap to tap the thread.

Insert the correct length cortex screw with the power tool using the hexagonal screwdriver shaft. For final tightening, assemble the screwdriver shaft to the handle and tighten the screw.

- ❶ Before proceeding, use clinical examination and fluoroscopy to confirm that:
  - the plate is orientated properly on the tibial plateau.
  - screw trajectories in the proximal locking holes are parallel to the joint in the transverse plane.
  - the alignment of the plate to the shaft of the tibia is correct in both the AP and lateral views.

At this point of the surgery the wires for preliminary fixation can be taken out.

**Note:** In depressed tibial plateau fractures, the use of bone void fillers to support the plateau surface may be beneficial.

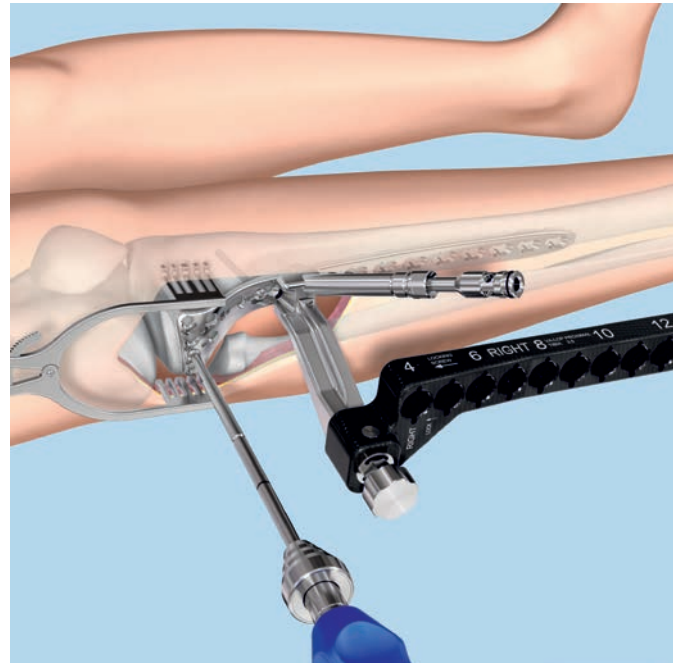

## 5. Secure aiming arm to plate distally

### Instruments

03.113.010	Trocar with Handle Ø 6.0 mm
03.127.010	Guide Sleeve for Aiming Arm Instruments for VA Plates 3.5
03.113.022	Centering Sleeve, percutaneous, for Kirschner Wire Ø 1.6 mm
02.113.001	Kirschner Wire Ø 1.6 mm, with drill tip, length 200 mm, Cobalt Chrome Alloy
321.160	Combination Wrench Ø 11.0 mm
314.160	Allen Key, small, Ø 2.5 mm, angled

Use the combination wrench and Allen key to make sure that all connections between aiming arm, insertion handle and plate are still fully tightened. To avoid screw hole damage or disassembly problems, make sure not to tighten any connection excessively. To avoid undesirable movement in the aiming arm system, the aiming arm must be secured distally to the plate and bone.

Locate the hole in the aiming arm that corresponds to the most distal combi-hole in the plate. The numbering on the aiming arm indicates the hole location on the plate. Make a skin incision at this location.

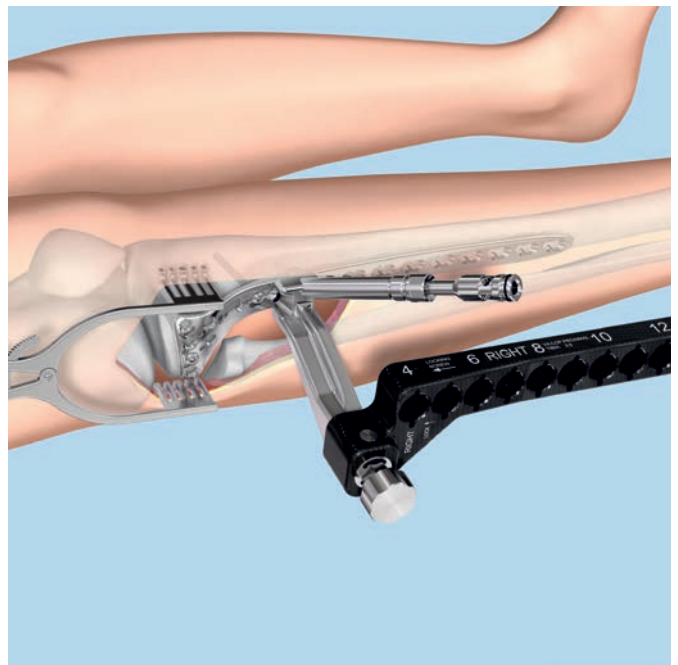
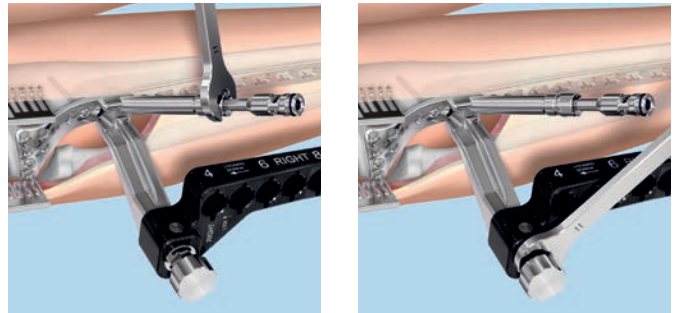

---

**Notes:**

- When using a plate with more than 12 holes, perform a careful soft tissue dissection down to the plate before inserting the trocar and guide sleeve in order to visualize and protect the superficial peroneal nerve and anterior neurovascular bundle.
- In patients of short stature the critical area may be reached with a shorter plate.

---

**Optional instrument**

03.113.011 Scalpel for Percutaneous Aiming Arm Instruments

---

Attach a blade to the scalpel handle. The scalpel handle will pass through the aiming arm holes and assist in performing an accurate and minimally invasive incision.

The scalpel handle should be inserted, backed out, rotated 180°, and reinserted. An adequate incision must be made to avoid soft tissue impingement when inserting a drill guide or wire guide. Then remove the scalpel from the aiming arm.

**Note:** Always remove the scalpel blade before storage in the case.

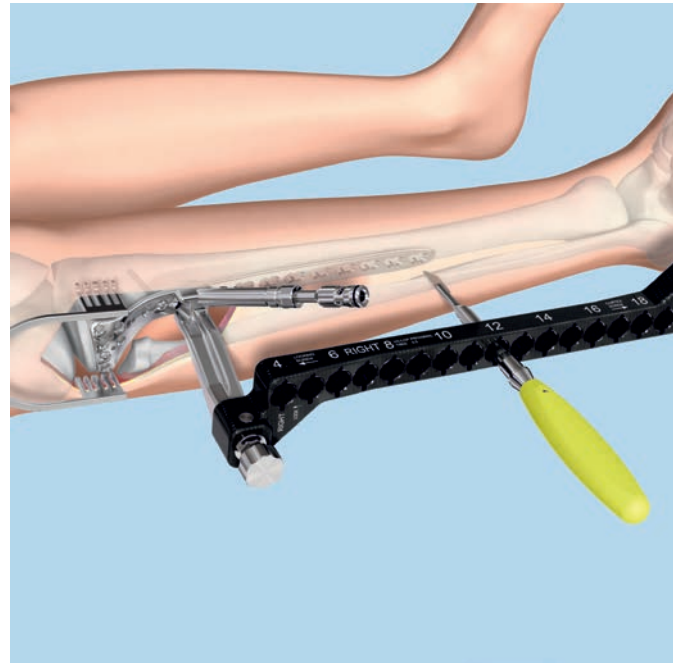

Assemble the trocar with handle with a guide sleeve. Orient the arrow on the guide sleeve in the direction of the "LOCKING SCREW" arrow on the aiming arm. Use the assembled trocar and guide sleeve to push down to the plate through the incision.

Push the assembly down until it snaps completely into the aiming arm. Make sure not to place excessive pressure on the guide sleeve as deflection can occur between the guide sleeve and the plate.

Remove the trocar. Insert the percutaneous centering sleeve into the guide sleeve and securely thread it into the most distal plate hole.

---

### Optional instrument

---

03.113.014 Handle for Drill Sleeves with thread

---

A handle can be attached to the centering sleeve to facilitate insertion. Turn the handle counterclockwise to disengage and remove it from the guide sleeve.

Insert a Kirschner wire  $\varnothing$  1.6 mm through the centering sleeve into the bone after the appropriate plate position has been found.

---

### Alternative instruments

---

03.113.020 Locking Drill Sleeve  $\varnothing$  2.8 mm, percutaneous

---

03.113.024 Drill Bit  $\varnothing$  2.8 mm with Stop, calibrated, length 250/225 mm, for Quick Coupling

---

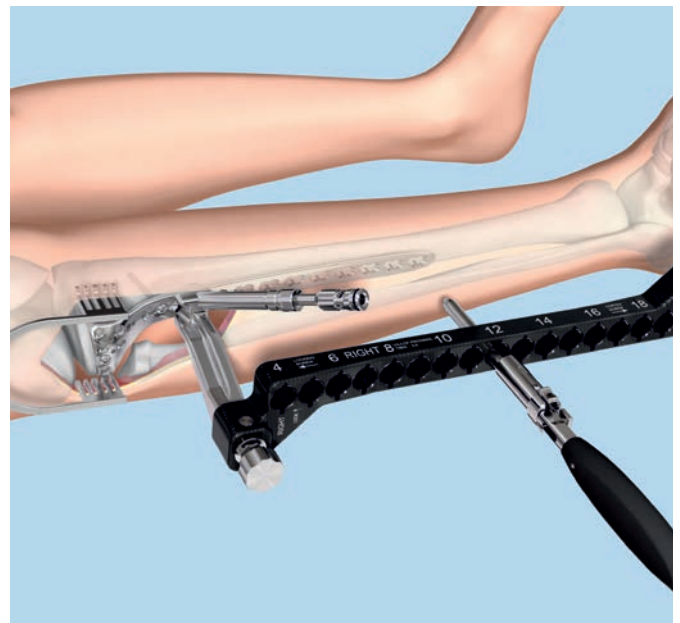
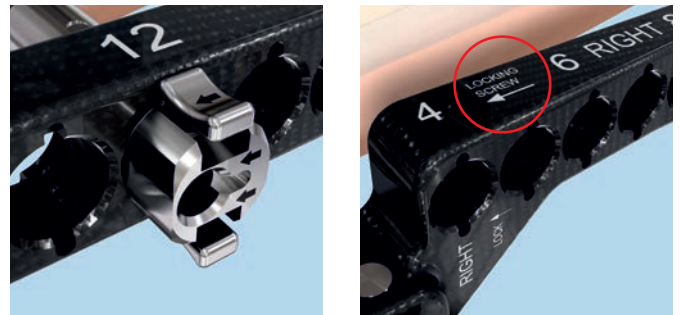

Alternatively, a locking drill sleeve and a drill bit can be used to stabilize the distal portion of the plate on the bone. Use the drill bit  $\varnothing$  2.8 mm to drill through the locking drill sleeve to the far cortex.

**Notes:**

- After closing the aiming arm “frame” distally, the range of eccentric compression is limited.
- For clear visualization, soft tissue is not shown in the following steps.

Tighten all connections before proceeding.

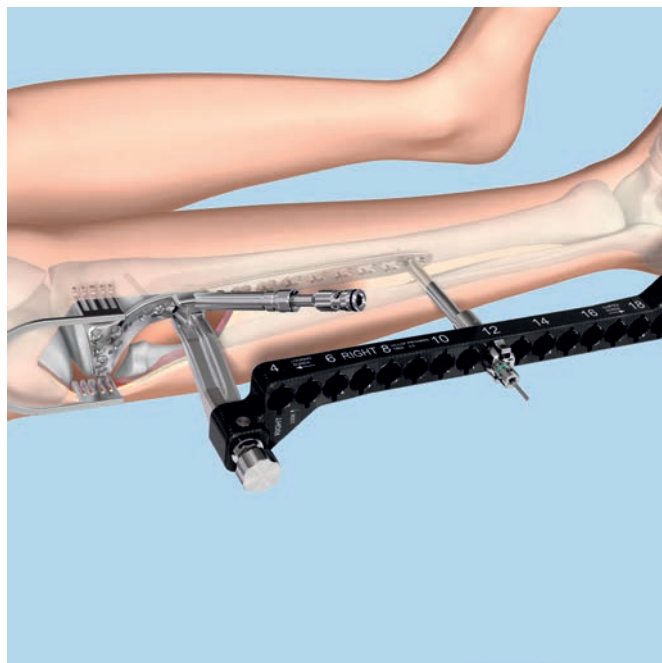

## 6. Use pull reduction device

### Instruments

03.127.010	Guide Sleeve for Aiming Arm Instruments for VA Plates 3.5
03.113.015	Pull Reduction Device for Outer Sleeve, for LCP Percutaneous Aiming Instruments 3.5*
321.160	Combination Wrench $\varnothing$ 11.0 mm

The insertion of the first screw in the plate shaft may push the bone medially, especially in case of dense bone and/or unstable reduction. The pull reduction device helps to solve this problem. Alternatively, a cortex screw can be used.

The pull reduction device must be used with a guide sleeve and in the locking portion of the plate. Orient the arrow on the guide sleeve in the direction of the "LOCKING SCREW" arrow on the aiming arm. Thread the nut for the pull reduction device over the tip of the pull reduction device.

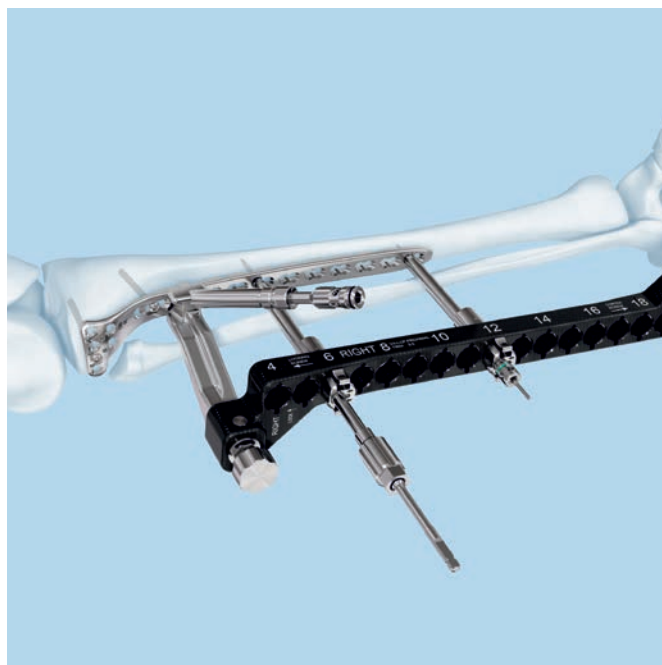

\* The nut is included in 03.113.015 and can be reordered under 03.113.016 (Nut for Pull Reduction Device).

With the nut in its highest position, attach the pull reduction device to a power tool with quick coupling and insert it through a guide sleeve.

**Note:** When inserting the pull reduction device, carefully monitor the advance of the tip.

- ① Remove the power tool and begin tightening the nut toward the drill guide while monitoring progress under radiographic imaging. This will pull the bone towards the plate and fix it in that position.

**Note:** A combination wrench may be used to facilitate tightening and loosening of the nut.

Stop when the desired reduction is achieved. Do not tighten the nut excessively.

**Note:** The predrilled hole allows the later placement of a VA locking screw  $\varnothing$  3.5 mm in the same hole.

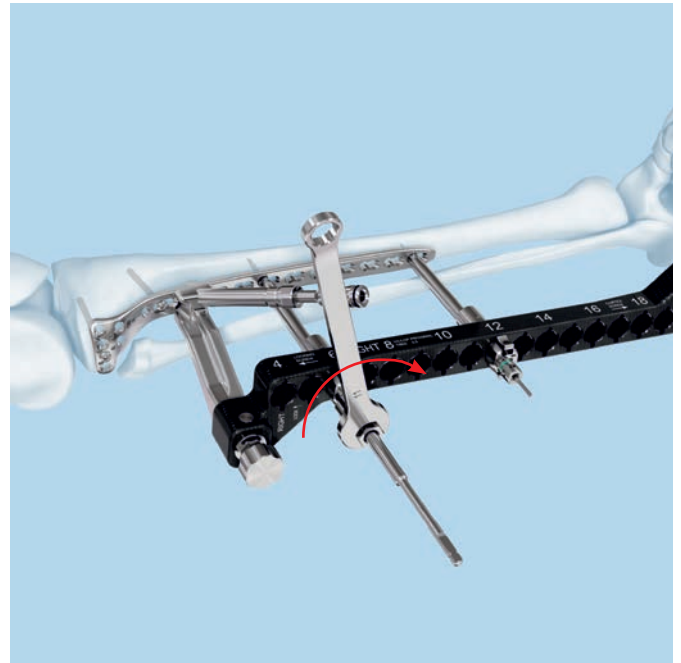

# Screw Insertion in the Plate Head

## 1. Insert VA locking screws $\varnothing$ 3.5 mm in proximal row

### Option A. Insert VA locking screws in fixed angle (non-angled position)

#### Instruments

03.127.001	VA Fixed Angle Drill Guide 3.5, for Drill Bits 2.8 mm
324.214	Drill Bit $\varnothing$ 2.8 mm, with Scale, length 200/100 mm, 3-flute, for Quick Coupling
03.127.016	Handle with Torque Limiting Function, 2.5 Nm
03.113.019	Screwdriver Shaft 3.5 Stardrive, T15, long, self-holding, for AO/ASIF Quick Coupling

Insert the VA fixed angle drill guide into a plate hole of the proximal rafting row. The drill guide is designed to be inserted into the plate to avoid an incorrect angle when threading it in.

Drill through the drill guide using the drill bit  $\varnothing$  2.8 mm. The four proximal rafting screws should be placed both parallel to the joint axis and parallel to each other. Advance the drill bit until it reaches the medial wall of the tibial condyle.

**Note:** Monitor the direction of the drill bit carefully when drilling. Although the fixed angle drill guide limits the range of motion, a completely fixed angle cannot be guaranteed.

**Precaution:** Make sure not to penetrate the articular surface (even in zero position a penetration is possible in unusual tibial plateau inclinations) or to cause screw collision. Furthermore, to avoid degeneration of the overlying articular cartilage, do not place screws too close to the tibial plateau.



Read the measurement from the calibrated drill bit  $\varnothing$  2.8 mm. Remove the drill bit and drill guide.

Insert the appropriate length VA locking screw. The VA locking screw  $\varnothing$  3.5 mm may be inserted using a power tool and the screwdriver shaft Stardrive T15. Final tightening must be done by hand using the screwdriver shaft Stardrive T15 together with the handle with torque limiting function 2.5 Nm.

**Note:** Confirm screw position and length prior to final tightening with the handle with torque limiting function 2.5 Nm.



---

**Alternative instrument**

---

03.127.002      VA Double Drill Guide 3.5,  
for Drill Bits  $\varnothing$  2.8 mm

---

Alternatively, the straight end of the VA double drill guide may be used for predrilling. The VA double drill guide allows either off-axis drilling (funnel end) or fixed angle drilling (straight end).

**Note:** Insert the fixed angle screws first, then insert the variable angle screws. Place the variable angle screws around the fixed angle screws.

Repeat the steps above to insert additional screws.



## Option B. Insert VA locking screws in variable angle

### Instruments

03.127.002	VA Double Drill Guide 3.5, for Drill Bits $\varnothing$ 2.8 mm
324.214	Drill Bit $\varnothing$ 2.8 mm, with Scale, length 200/100 mm, 3-flute, for Quick Coupling
319.090	Depth Gauge for Long Screws $\varnothing$ 3.5 mm, measuring range up to 110 mm
03.127.016	Handle with Torque Limiting Function, 2.5 Nm
03.113.019	Screwdriver Shaft 3.5 Stardrive, T15, long, self-holding, for AO/ASIF Quick Coupling

Insert the funnel-shaped end of the double drill guide into a plate hole of the proximal rafting row. The drill guide is designed to be inserted into the plate to avoid an incorrect angle when threading it in.

Drill through the double drill guide at the desired angle using the drill bit  $\varnothing$  2.8 mm. The four proximal rafting screws should be placed parallel to the joint axis. Their angle can be adapted to the tibial plateau inclination. Advance the drill bit until it reaches the medial wall of the tibial condyle.

**Note:** Monitor the direction of the drill bit carefully when drilling.

**Precaution:** Make sure not to penetrate the articular surface or to cause screw collision.

Remove the drill bit and drill guide and use the depth gauge to measure for screw length.



Insert the appropriate length VA locking screw. The VA locking screw  $\varnothing$  3.5 mm may be inserted using a power tool and the screwdriver shaft Stardrive T15. Final tightening must be done by hand using the screwdriver shaft Stardrive T15 together with the handle with torque limiting function 2.5 Nm.

**Note:** Confirm screw position and length prior to final tightening with the handle with torque limiting function 2.5 Nm.

Repeat the steps above to insert additional screws.



## 2. Insert VA locking screws $\varnothing$ 3.5 mm in second row

### Option A. Insert VA locking screws in fixed angle (non-angled position)

#### Instruments

03.127.001	VA Fixed Angle Drill Guide 3.5, for Drill Bits $\varnothing$ 2.8 mm
324.214	Drill Bit $\varnothing$ 2.8 mm, with Scale, length 200/100 mm, 3-flute, for Quick Coupling
03.127.016	Handle with Torque Limiting Function, 2.5 Nm
03.113.019	Screwdriver Shaft 3.5 Stardrive, T15, long, self-holding, for AO/ASIF Quick Coupling

To insert fixed angle VA locking screws in the second row, follow the procedure described in Step 1.

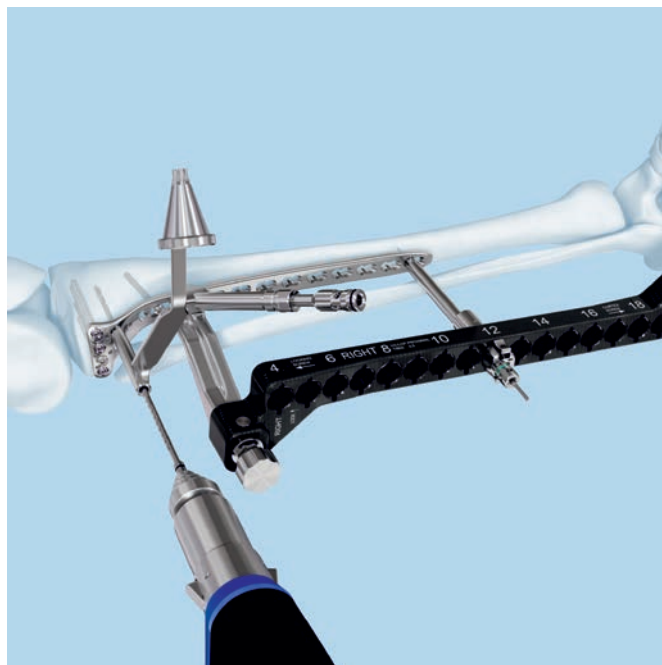

## Option B. Insert VA locking screws in variable angle

### Instruments

03.127.002	VA Double Drill Guide 3.5, for Drill Bits $\varnothing$ 2.8 mm
324.214	Drill Bit $\varnothing$ 2.8 mm, with Scale, length 200/100 mm, 3-flute, for Quick Coupling
319.090	Depth Gauge for Long Screws $\varnothing$ 3.5 mm, measuring range up to 110 mm
03.127.016	Handle with Torque Limiting Function, 2.5 Nm
03.113.019	Screwdriver Shaft 3.5 Stardrive, T15, long, self-holding, for AO/ASIF Quick Coupling

To insert fixed angle VA locking screws in the second row, follow the procedure described in Step 1.

**Note:** Should some plate head holes be empty, ensure that the screws are distributed between the proximal and the second row rather than filling the proximal row only.

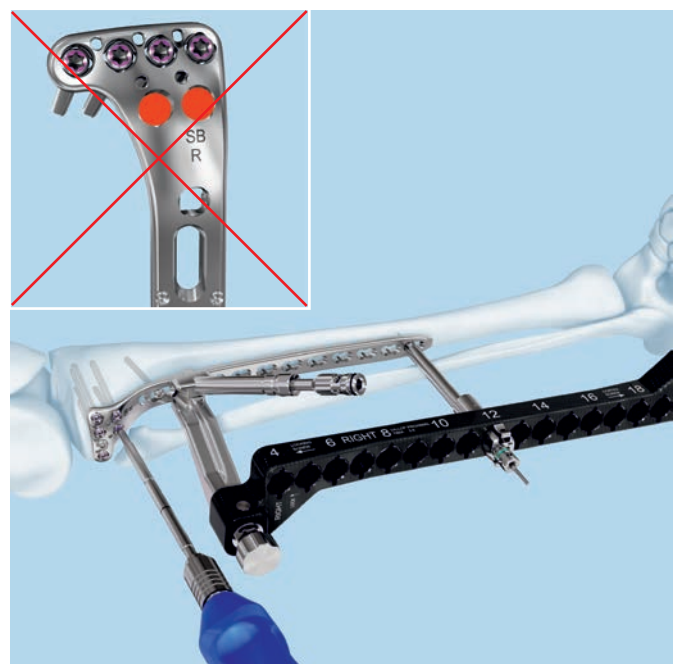

# Screw Insertion in the Plate Shaft

## 1. Insert cortex screws $\varnothing$ 3.5 mm in plate shaft

### Instruments

03.127.010	Guide Sleeve for Aiming Arm Instruments for VA Plates 3.5
03.113.010	Trocar with Handle $\varnothing$ 6.0 mm
03.113.012	Drill Sleeve $\varnothing$ 2.5 mm, for neutral position, percutaneous
or	
03.113.013	Drill Sleeve $\varnothing$ 2.5 mm, for compression position, percutaneous
03.113.023	Drill Bit $\varnothing$ 2.5 mm with Stop, calibrated, length 250/225 mm, for Quick Coupling
314.550	Screwdriver Shaft, hexagonal, small, $\varnothing$ 2.5 mm, length 165 mm, for Quick Coupling
03.019.005	Handle with Quick Coupling, length 150 mm

Choose an aiming arm hole through which to make an incision.

### Notes:

- When using a plate with more than 12 holes, perform a careful soft tissue dissection down to the plate before inserting the trocar and guide sleeve in order to visualize and protect the superficial peroneal nerve and anterior neurovascular bundle.
- In patients of short stature the critical area may be reached with a shorter plate.

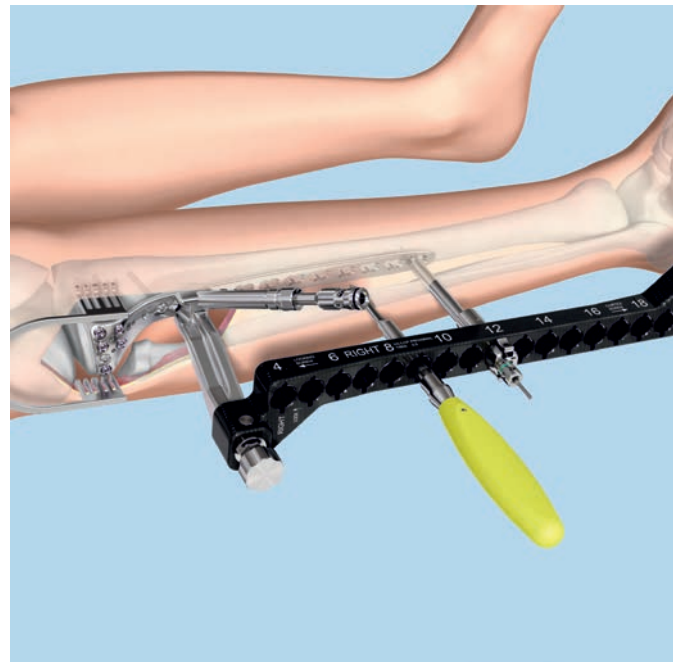
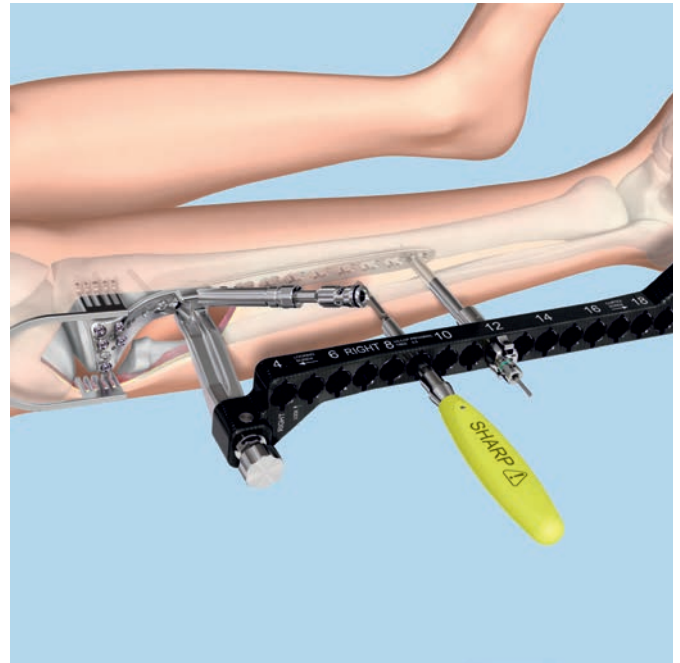

---

### Optional instrument

---

03.113.011 Scalpel for Percutaneous Aiming Arm Instruments

---

Optionally, the scalpel handle can be used. Attach a blade to the scalpel handle. The scalpel handle will pass through the aiming arm holes and assist in performing a minimally invasive and accurate incision.

The scalpel handle should be inserted, backed out, rotated 180°, and reinserted. An adequate incision must be made to avoid soft tissue impingement when inserting a drill guide or wire guide. Then remove the scalpel from the aiming arm.

**Note: Always remove the scalpel blade before storage in the case.**

Assemble the trocar with handle with a guide sleeve.

Orient the arrow on the guide sleeve in the direction of the "CORTEX SCREW" arrow on the aiming arm.

Use the assembled trocar and guide sleeve to push down to the plate through the incision. Push the assembly down until it snaps completely into the aiming arm.

Remove the trocar.

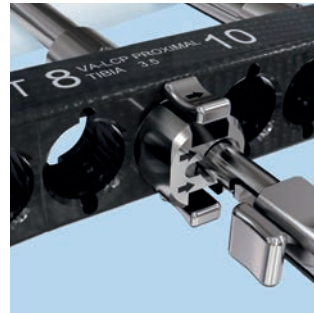

Choose an appropriate drill sleeve, either for neutral or load position, and insert it into the guide sleeve until it snaps securely into place.

When positioning the drill sleeve, make sure that the open ends of the instruments are oriented towards the clamping mechanism of the guide sleeve.

**Note:** When using the compression drill sleeve, it is important to insert the drill sleeve in the proper orientation into the guide sleeve as shown on the picture on the left.

**Note:** After closing the aiming arm “frame” distally, the range of eccentric compression is limited.

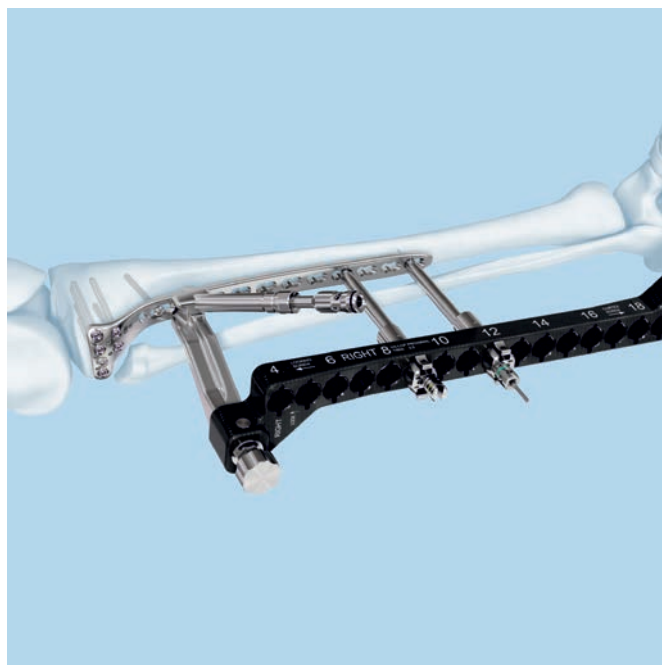
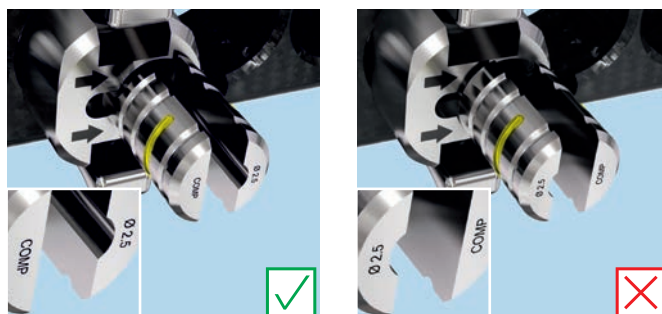

Use the drill bit  $\varnothing$  2.5 mm with stop to drill to the desired depth. Verify that the plastic stop sits on the drill sleeve before removing the drill bit (1).

Remove the drill bit and read the drill depth indicated below the plastic stop (2). The first visible number indicates the correct depth.

Remove the drill sleeve by gently depressing its release mechanism and slowly pulling it away from the guide sleeve.

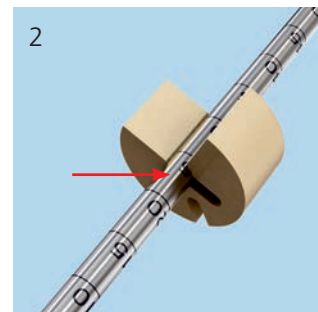
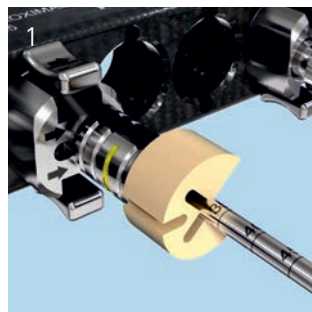

---

**Alternative instrument**

---

03.113.028      Depth Gauge for Percutaneous Aiming Arm Instruments

---

Alternatively, screw length can be determined with the help of the depth gauge. Remove the drill sleeve and insert the depth gauge into the guide sleeve to the previously drilled depth. The screw length is indicated by the gauge marking aligned with the top of the guide sleeve. Remove the depth gauge.

Insert the appropriate length cortex screw. The cortex screw may be inserted using a power tool and the hexagonal screwdriver shaft. Switch to manual screw insertion using the screwdriver shaft with handle when the marking on the screwdriver shaft approaches the end of the guide sleeve.



---

**Optional instrument**

---

03.127.011 Stopper for Aiming Arm,  
for VA Plates 3.5

---

Mark each screw location in the aiming arm using a stopper for reference as screw insertion proceeds.

Repeat the steps above to insert additional screws.

**Note:** All cortex screws  $\varnothing$  3.5 mm must be inserted before inserting locking screws.

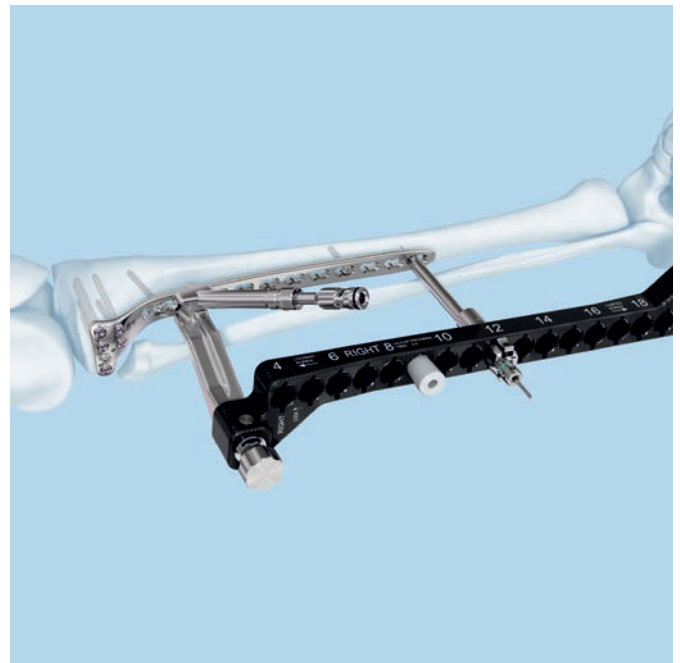

## 2. Insert VA locking screws $\varnothing$ 3.5 mm in plate shaft

### Option A: Insert VA locking screws in fixed angle over aiming arm

#### Instruments

03.127.010	Guide Sleeve for Aiming Arm Instruments for VA Plates 3.5
03.113.010	Trocar with Handle $\varnothing$ 6.0 mm
03.113.020	Locking Drill Sleeve $\varnothing$ 2.8 mm, percutaneous
03.113.024	Drill Bit $\varnothing$ 2.8 mm with Stop, calibrated, length 250/225 mm, for Quick Coupling
03.113.019	Screwdriver Shaft 3.5 Stardrive, T15, long, self-holding, for AO/ASIF Quick Coupling
03.127.016	Handle with Torque Limiting Function, 2.5 Nm
314.160	Allen Key, small, $\varnothing$ 2.5 mm, angled

Choose an aiming arm hole through which to make an incision and create the incision. Optionally, the scalpel handle can be used.

#### Notes:

- When using a plate with more than 12 holes, perform a careful soft tissue dissection down to the plate before inserting the trocar and guide sleeve in order to visualize and protect the superficial peroneal nerve and anterior neurovascular bundle.
- In patients of short stature the critical area may be reached with a shorter plate.



Assemble the trocar with handle with a guide sleeve. Orient the arrow on the guide sleeve in the direction of the "LOCKING SCREW" arrow on the aiming arm.

Use the assembled trocar and guide sleeve to push down to the plate through the incision. Push the assembly down until it snaps completely into the aiming arm. Remove the trocar.

Insert the locking drill sleeve into the guide sleeve and securely thread it into the plate. To facilitate the insertion, the handle 03.113.014 can be used.

Use the calibrated drill bit  $\varnothing$  2.8 mm with stop to drill to the desired depth. Verify that the plastic stop sits on the drill sleeve before removing the drill bit (1).

Remove the drill bit and read the indicated drill depth below the plastic stop (2). The first number visible indicates the correct depth.

Alternatively, screw length can be determined with the help of the depth gauge (see page 36).

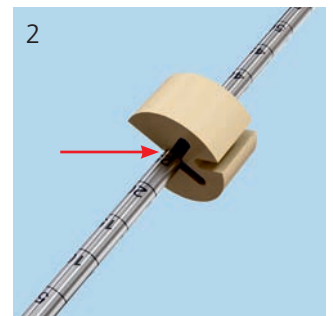

Insert the appropriate length VA locking screw. The VA locking screw  $\varnothing$  3.5 mm may be inserted using a power tool and the screwdriver shaft Stardrive T15. Final tightening must be done by hand using the screwdriver shaft Stardrive T15 together with the handle with torque limiting function 2.5 Nm. Switch to manual screw insertion when the marking on the screwdriver shaft approaches the end of the guide sleeve.

**Note:** Confirm screw position and length prior to final tightening with the handle with torque limiting function 2.5 Nm.

Mark each screw location in the aiming arm using a stopper for reference as screw insertion proceeds.

Repeat the steps above to insert additional screws.

**Note:** Use the Allen key to loosen the locking drill sleeve from the plate.

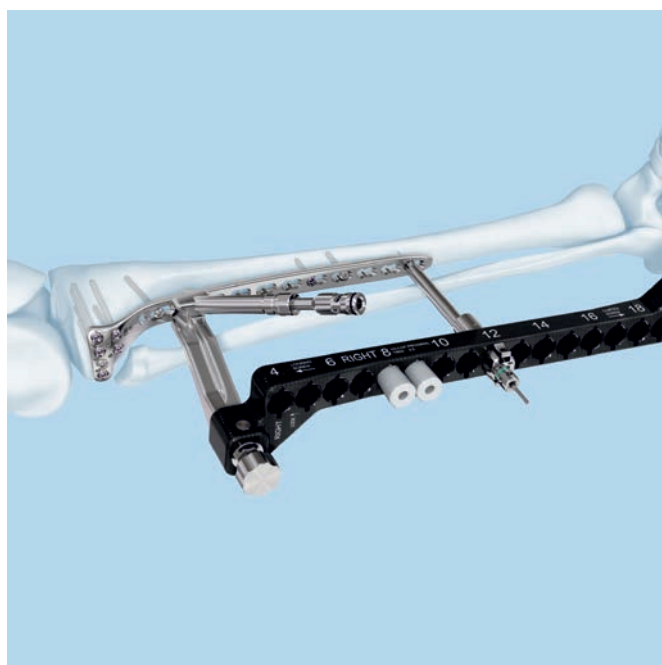
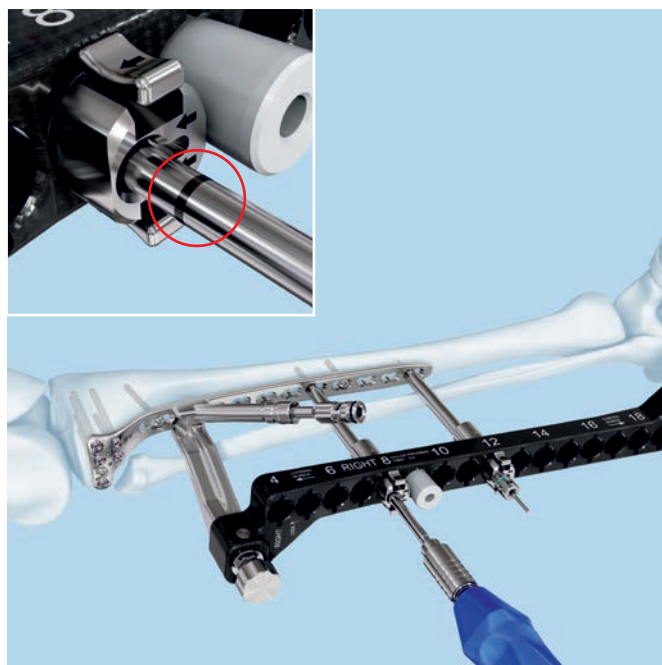

## Option B: Insert VA locking screws in variable angle over freehand drill guide

### Instruments

03.127.004	VA Drill Guide 3.5, for Drill Bits $\varnothing$ 2.8 mm, long, with spherical head
03.127.005	Trocar for VA Drill Guide 3.5, for Drill Bits $\varnothing$ 2.8 mm, long, with spherical head
03.127.006	Protection Sleeve for VA Drill Guide 3.5, for Drill Bits $\varnothing$ 2.8 mm, long, with spherical head
03.113.024	Drill Bit $\varnothing$ 2.8 mm with Stop, calibrated, length 250/225 mm, for Quick Coupling
03.113.019	Screwdriver Shaft 3.5 Stardrive, T15, long, self-holding, for AO/ASIF Quick Coupling
03.127.016	Handle with Torque Limiting Function, 2.5 Nm

Assemble the freehand drill guide: thread the VA drill guide into the protection sleeve and insert the trocar into the VA drill guide.

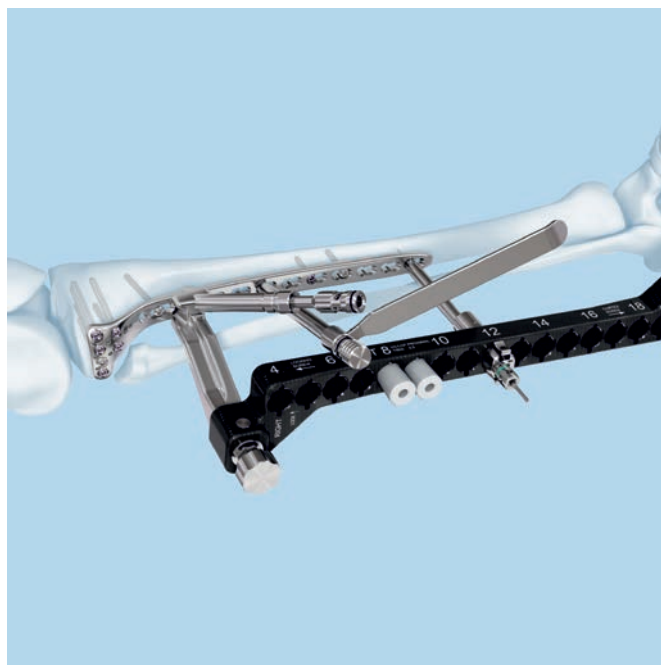
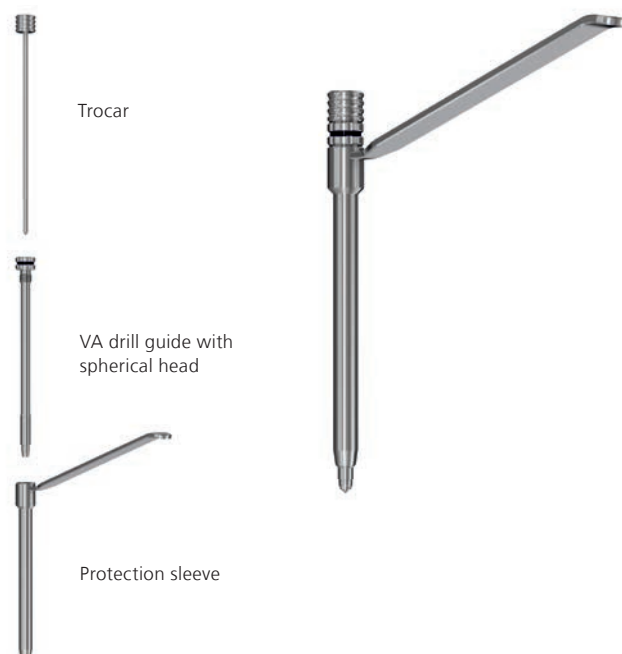

Depending on the desired angle, the trocar/drill guide/protection sleeve assembly may be placed through the aiming arm hole, or it may be placed outside of the aiming arm. The aiming arm helps to locate the hole. Choose an aiming arm hole through which to make an incision. When using the instrument outside of the aiming arm, it may be necessary to extend the cut.

**Notes:**

- When using a plate with more than 12 holes, perform a careful soft tissue dissection down to the plate before inserting the trocar and guide sleeve in order to visualize and protect the superficial peroneal nerve and anterior neurovascular bundle.
- In patients of short stature the critical area may be reached with a shorter plate.

Insert the assembly to the plate through the previously created incision. The spherical tip of the VA drill guide should be gently pressed into the variable angle hole to prevent drilling beyond 15°. Remove the trocar from the assembly.

Use the calibrated drill bit  $\varnothing$  2.8 mm with stop to drill to the desired depth. Verify that the plastic stop sits on the drill guide. Remove the drill bit and read the indicated drill depth below the plastic stop as described in Option A.

**Note:** The long drill bit  $\varnothing$  2.8 mm is calibrated for the VA Drill Guide 3.5 (03.127.004) and for the percutaneous Locking Drill Sleeve (03.113.020).

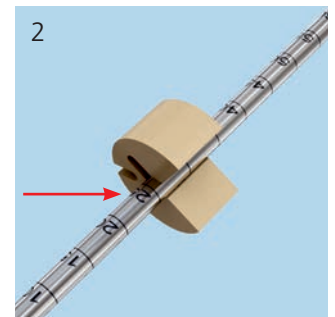
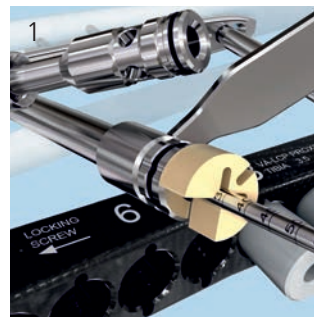

Remove the drill bit and prepare the appropriate length VA locking screw. Carefully remove the drill guide and make sure that the protection sleeve remains in the proper position above the screw hole.

Insert the screw through the protection sleeve. The VA locking screw  $\varnothing$  3.5 mm may be inserted using a power tool and the screwdriver shaft Stardrive T15. Final tightening must be done by hand using the screwdriver shaft Stardrive T15 together with the handle with torque limiting function 2.5 Nm.

**Note:** Confirm screw position and length prior to final tightening with the handle with torque limiting function 2.5 Nm.

Repeat the steps above to insert additional screws.



# Screw Insertion in the Plate Neck

## 1. Aiming arm removal

### Instruments

314.160 Allen Key, small, Ø 2.5 mm, angled

321.160 Combination Wrench Ø 11.0 mm

In case an aiming arm has been used, detach it from the plate before predrilling the angled holes in the plate neck.

### Alternative instruments

03.124.006 Cannulated Interlocking Bolt 2.8 mm

03.113.024 Drill Bit Ø 2.8 mm with Stop, calibrated, length 250/225 mm, for Quick Coupling

Alternatively, predrilling can be done with the long drill bit with stop through the cannulated interlocking bolt still connected to the insertion handle and plate. The required length can be read off the drill bit calibration below the plastic stop.

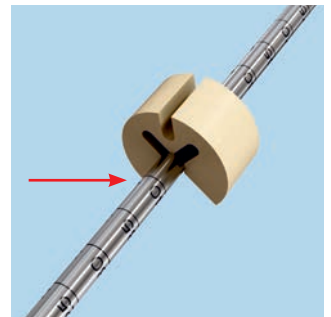
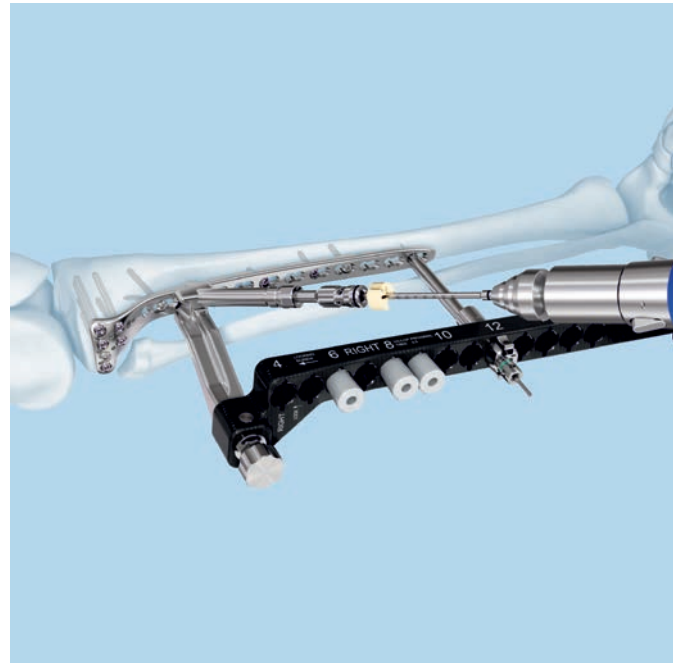

---

Remove all aiming arm instruments prior to screw insertion.

To remove the aiming arm, remove all guide sleeves, drill sleeves and the pull reduction device.

Turn the connecting bolt on the aiming arm counterclockwise to loosen it and remove the aiming arm from the insertion handle.

Turn the interlocking nut and then the interlocking bolt counterclockwise and remove the interlocking bolt with nut and the insertion handle.

**Note:** Use the Allen key to loosen locking drill sleeves, centering sleeves and the interlocking bolt. Use the combination wrench to loosen the connection bolt of the aiming arm and the nut on the interlocking bolt.

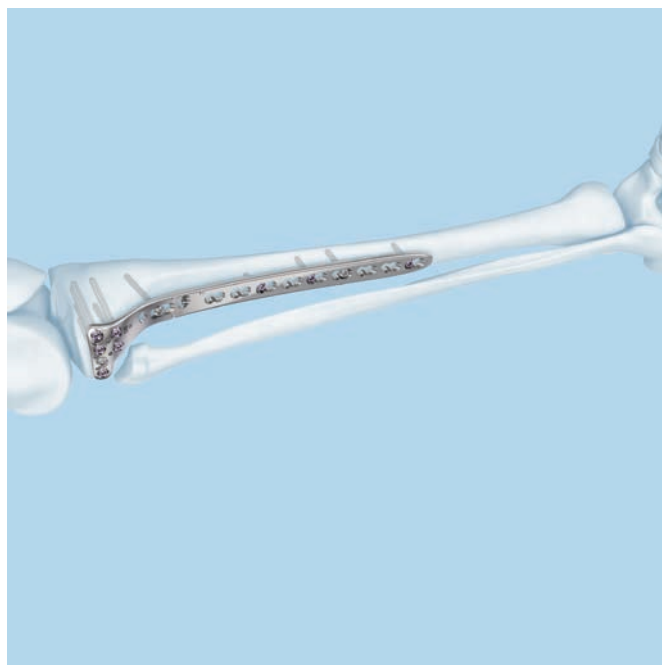
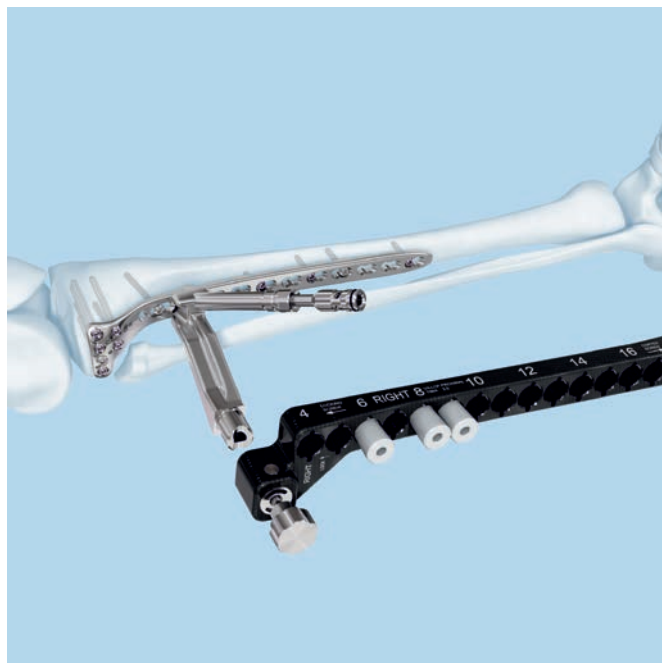

## 2. Insert VA locking screw $\varnothing$ 3.5 mm in distal neck hole

### Instruments

03.127.001	VA Fixed Angle Drill Guide 3.5, for Drill Bits $\varnothing$ 2.8 mm
324.214	Drill Bit $\varnothing$ 2.8 mm, with Scale, length 200/100 mm, 3-flute, for Quick Coupling
03.127.016	Handle with Torque Limiting Function, 2.5 Nm
03.113.019	Screwdriver Shaft 3.5 Stardrive, T15, long, self-holding, for AO/ASIF Quick Coupling

Drill through the drill guide using the drill bit  $\varnothing$  2.8 mm. Advance the drill bit until it reaches the medial wall of the tibial condyle.

**Note:** Monitor the direction of the drill bit carefully when drilling. Although the fixed angle drill guide limits the range of motion a completely fixed angle cannot be guaranteed.

**Precaution:** Make sure not to cause screw collision, especially if the second row screws have been angled away from the nominal axis.

### Alternative Instrument

03.127.002	VA Double Drill Guide 3.5, for Drill Bits $\varnothing$ 2.8 mm
------------	--

Alternatively, the VA double drill guide may be used for predrilling in fixed or variable angle position.

Read the measurement from the calibrated drill bit  $\varnothing$  2.8 mm. Remove the drill bit and drill guide.

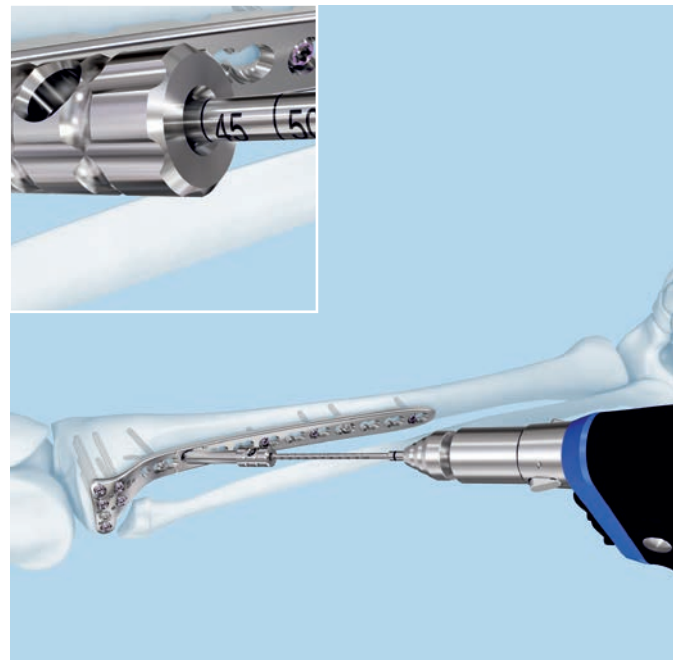
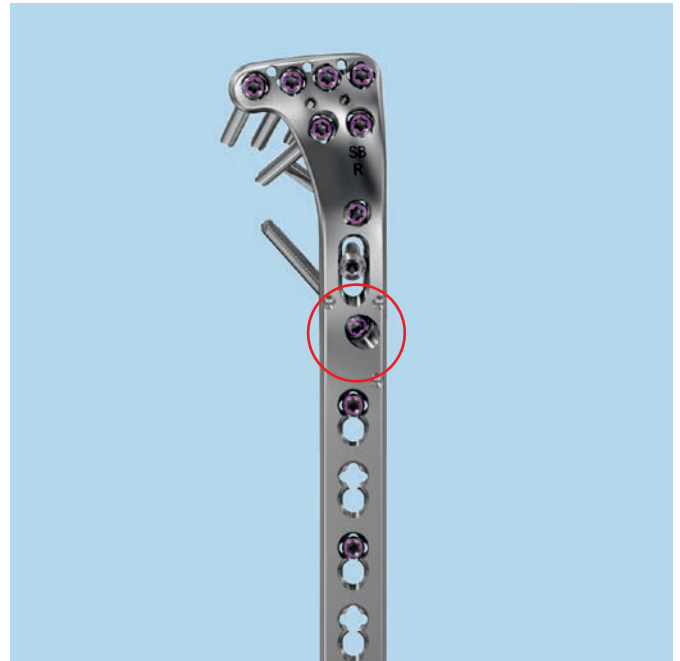

Insert the appropriate length VA locking screw. The VA locking screw  $\varnothing$  3.5 mm may be inserted using a power tool and the screwdriver shaft Stardrive T15. Final tightening must be done by hand using the screwdriver shaft Stardrive T15 together with the handle with torque limiting function 2.5 Nm.

**Note:** Confirm screw position and length prior to final tightening with the handle with torque limiting function 2.5 Nm.

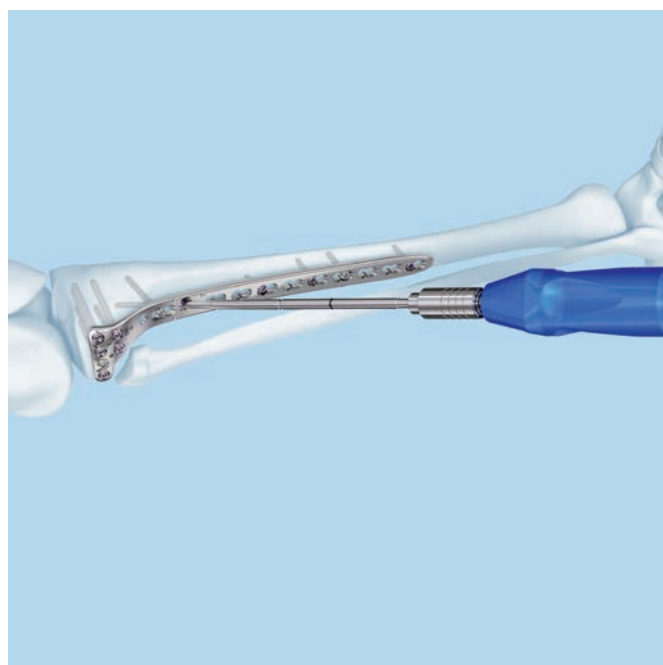
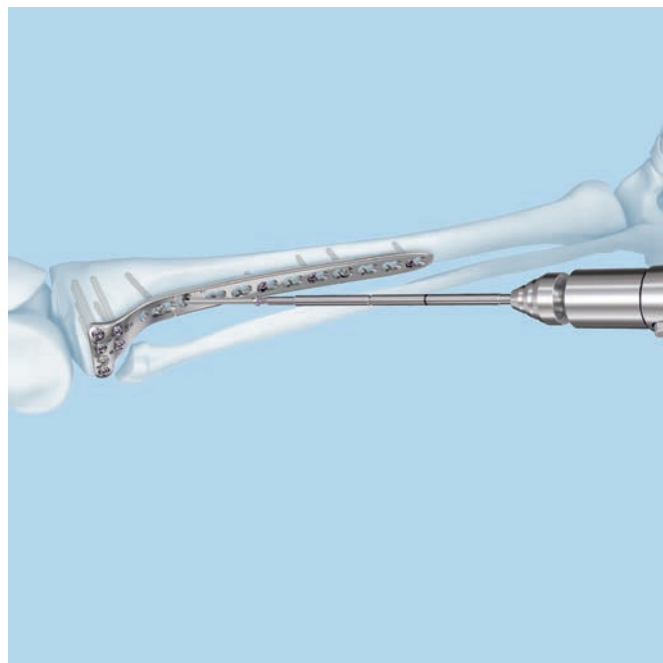

### 3. Insert VA locking screw $\varnothing$ 3.5 mm in proximal neck hole

#### Instruments

03.127.001	VA Fixed Angle Drill Guide 3.5, for Drill Bits $\varnothing$ 2.8 mm
324.214	Drill Bit $\varnothing$ 2.8 mm, with Scale, length 200/100 mm, 3-flute, for Quick Coupling
03.127.016	Handle with Torque Limiting Function, 2.5 Nm
03.113.019	Screwdriver Shaft 3.5 Stardrive, T15, long, self-holding, for AO/ASIF Quick Coupling

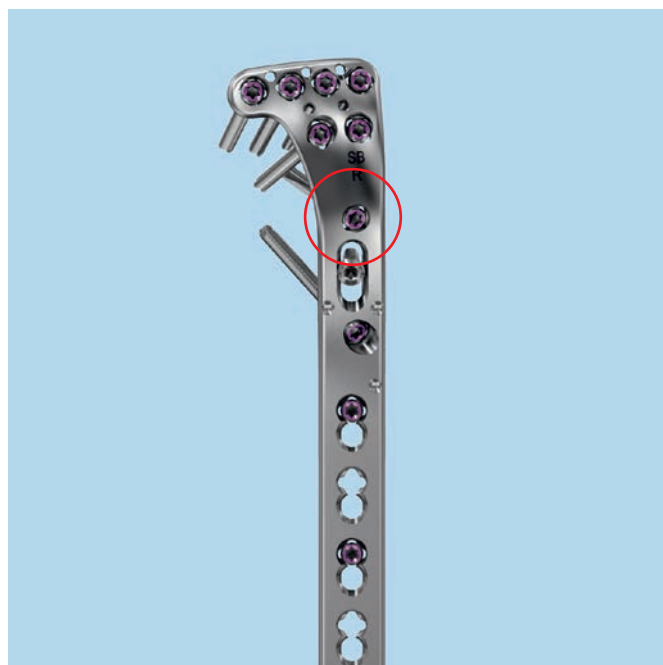

---

Insert a VA fixed angle drill guide into the proximal neck hole and follow the procedure described in Step 1.

Alternatively, the VA double drill guide may be used for predrilling in fixed or variable angle position.

**Precaution:** Make sure not to cause screw collision, especially if the proximal row screws have been angled away from the nominal axis.

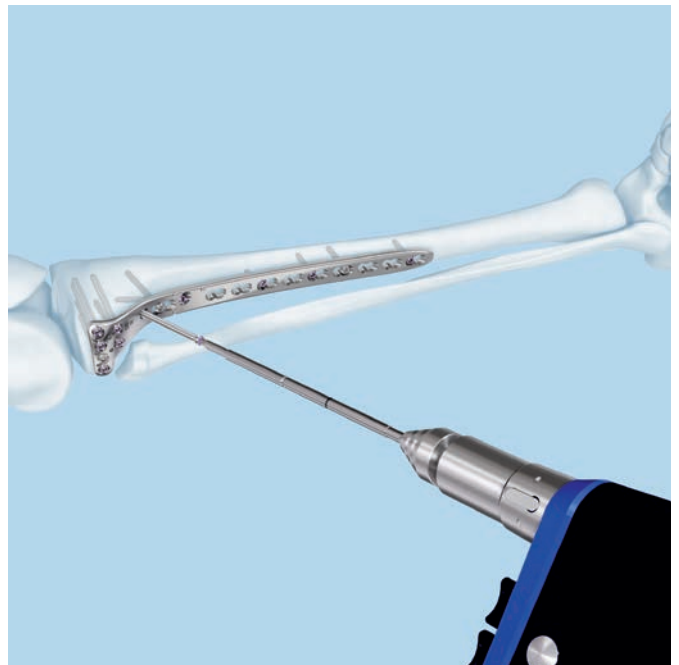

# Closure

---

Reattach the lateral meniscus either to the remaining rim of the capsule or to the most proximal small holes in the plate and perform wound closure.

In general, to facilitate screw removal at a later stage, please include the type of screws recess used in the surgery report.

# Implant Removal

---

## 1. Removal technique

In case the physician decides to remove the implants, they can be removed by using general surgical instruments.

Remove the implant only after complete consolidation of the fracture. Remove in reverse order to the implantation.

First, make the incision in the path of the old scar. If an aiming arm was used, assemble the insertion handle and aiming arm with the plate.

Make stab incisions and use the screwdriver shaft with the corresponding recess together with the handle with quick coupling (03.019.005) to unlock all screws manually. In a second step, completely remove all screws with a power tool.

### Notes:

- **When using a plate with more than 12 holes, perform a careful soft tissue dissection down to the plate before inserting the trocar and guide sleeve in order to visualize and protect the superficial peroneal nerve and anterior neurovascular bundle.**
- **In patients of short stature the critical area may be reached with a shorter plate.**

## 2. Tips for removal

### Screw Extraction Set

01.900.020 Extraction Set for Standard Screws

The Synthes screw extraction set contains the instruments required for removing intact screws or damaged screws that are difficult to remove.

The set includes:

- Screw-size-related extraction instruments (e.g. screwdriver shafts, conical extraction screws)
- General instruments for screw removal that can be used for all screw sizes
- Modular instrument trays for customized solutions

For details regarding implant removal refer to the surgical technique "Screw Extraction Set" DSEM/TRM/0614/0104.



### Stardrive

A Stardrive recess facilitates screw insertion and extraction:

- High torque transmission between screwdriver and screw recess even with half the insertion depth (e.g. in cases of soft-tissue ingrowth)
- Reduced screw recess deformation as prerequisite for successful screw extraction
- Improved instrument durability and higher resistance to corrosion
- Specific screwdriver designs suited for insertion (conical design, self-holding) and extraction (cylindrical design, rounded tip to locate the recess easily and to allow a maximum of torque transmission)

For details regarding Stardrive Recess refer to the flyer "Why stardrive" DSEM/TRM/0115/0306.

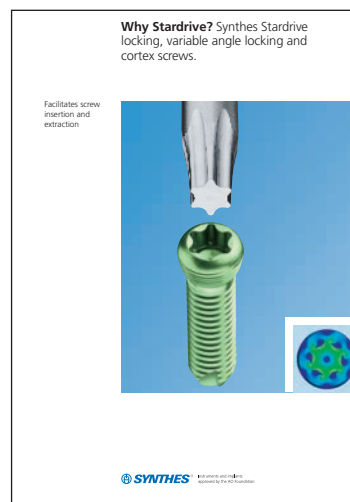

# Care and Maintenance

---

## **1. Recalibration of the Torque Limiting Handle 03.127.016**

A product-specific Instruction for Use (IFU) has been created for the Handle with Torque Limiting Function, 2.5 Nm (03.127.016). It includes all information regarding usage, recalibration, care and maintenance and is included in each package. Ensure to recalibrate the instrument as frequent as recommended (see SE\_452059 for further details).

---

## **2. General information regarding cleaning and sterilization**

For details regarding cleaning and sterilization, please consult the following page:  
[www.synthes.com/reprocessing](http://www.synthes.com/reprocessing)

# Plates

---

## Small bend plates

<b>Stainless Steel</b>	<b>Holes</b>	<b>Length (mm)</b>	<b>Side</b>
02.127.210	4	87	right
02.127.211	4	87	left
02.127.220	6	117	right
02.127.221	6	117	left
02.127.230	8	147	right
02.127.231	8	147	left
02.127.240	10	177	right
02.127.241	10	177	left
02.127.250	12	207	right
02.127.251	12	207	left
02.127.260	14	237	right
02.127.261	14	237	left



All plates are available sterile packed.  
For sterile implants add suffix S to article number.

---

**Large bend plates**

<b>Stainless Steel</b>	<b>Holes</b>	<b>Length (mm)</b>	<b>Side</b>
02.127.310	4	87	right
02.127.311	4	87	left
02.127.320	6	117	right
02.127.321	6	117	left
02.127.330	8	147	right
02.127.331	8	147	left
02.127.340	10	177	right
02.127.341	10	177	left
02.127.350	12	207	right
02.127.351	12	207	left
02.127.360	14	237	right
02.127.361	14	237	left



All plates are available sterile packed.  
For sterile implants add suffix S to article number.

# Screws

---

## VA Locking Screw Stardrive Ø 3.5 mm

May be used in all variable angle locking holes including the locking portion of the combi-holes.

- Threaded rounded head
- Self-tapping tip
- Stardrive recess
- Lengths 10–95 mm



---

Stainless Steel

02.127.110 – 02.127.195

The following existing screws are compatible with the VA-LCP Proximal Tibial Plate 3.5:

Locking screw Ø 3.5 mm

Cortex screw Ø 3.5 mm

## Locking Screw Ø 3.5 mm

**Note:** Locking screws Ø 3.5 mm must be inserted at zero degrees and must be tightened with 1.5 Nm Torque Limiter Attachment.

**Note:** It is recommended to use available guiding tools to assist insertion at zero degrees.

- Threaded conical head
- Self-tapping tip



## Cortex Screw Ø 3.5 mm

- May be used in the DCU portion of the VA locking combi-holes, in the long hole in the plate neck and in the plate head through a VA locking hole to create compression.
- Self-tapping tip
- Hexagonal recess
- Lengths 10 – 95 mm



# Instruments

---

## VA-Instruments

---

03.127.001 VA Fixed Angle Drill Guide 3.5,  
for Drill Bits  $\varnothing$  2.8 mm



---

03.127.002 VA Double Drill Guide 3.5,  
for Drill Bits  $\varnothing$  2.8 mm



---

03.127.004 VA Drill Guide 3.5, for Drill Bits  
 $\varnothing$  2.8 mm, long, with spherical head



---

03.127.005 Trocar for VA Drill Guide 3.5,  
for Drill Bits  $\varnothing$  2.8 mm, long,  
with spherical head



---

03.127.006 Protection Sleeve for VA Drill Guide 3.5,  
for Drill Bits  $\varnothing$  2.8 mm, long,  
with spherical head



---

03.127.012 Trial Implant for VA-LCP Proximal Tibial Plate 3.5, Small Bend, right, with 6 marked holes



---

03.127.013 Trial Implant for VA-LCP Proximal Tibial Plate 3.5, Small Bend, left, with 6 marked holes



---

03.127.014 Trial Implant for VA-LCP Proximal Tibial Plate 3.5, Large Bend, right, with 6 marked holes



---

03.127.015 Trial Implant for VA-LCP Proximal Tibial Plate 3.5, Large Bend, left, with 6 marked holes



---

03.127.016 Handle with Torque Limiting Function, 2.5 Nm



292.200.01	Kirschner Wire $\varnothing$ 2.0 mm with trocar tip, length 150 mm, Stainless Steel (also available in a pack of 10 pieces: 292.200.10)	
319.090	Depth Gauge for Long Screws $\varnothing$ 3.5 mm, measuring range up to 110 mm	
324.214	Drill Bit $\varnothing$ 2.8 mm, with Scale, length 200/100 mm, 3-flute, for Quick Coupling	
03.113.023	Drill Bit $\varnothing$ 2.5 mm with Stop, calibrated, length 250/225 mm, for Quick Coupling	
03.113.024	Drill Bit $\varnothing$ 2.8 mm with Stop, calibrated, length 250/225 mm, for Quick Coupling	

03.113.019 Screwdriver Shaft 3.5 Stardrive, T15, long, self-holding, for AO/ASIF Quick Coupling



314.550 Screwdriver Shaft, hexagonal, small, Ø 2.5 mm, length 165 mm, for Quick Coupling



03.019.005 Handle with Quick Coupling, length 150 mm



323.360 Universal Drill Guide 3.5



311.310 Tap for Cortex Screws Ø 3.5 mm, calibrated, length 175 mm



---

## Aiming Arm Instruments

---

03.127.007 Insertion Handle for Aiming Arm for VA-LCP Proximal Tibial Plate 3.5, right



---

03.127.008 Insertion Handle for Aiming Arm for VA-LCP Proximal Tibial Plate 3.5, left



---

03.127.009 Aiming Arm for VA-LCP Proximal Tibial Plate 3.5

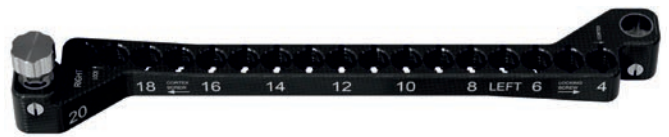

---

03.127.010 Guide Sleeve for Aiming Arm Instruments for VA Plates 3.5



---

03.127.011 Stopper for Aiming Arm, for VA Plates 3.5



---

03.124.004 Nut for Cannulated Interlocking Bolt



---

03.124.005 Cannulated Interlocking Bolt 1.6 mm



03.124.006 Cannulated Interlocking Bolt 2.8 mm



02.113.001 Kirschner Wire Ø 1.6 mm, with drill tip, length 200 mm, Cobalt Chrome Alloy



03.113.010 Trocar with Handle Ø 6.0 mm



03.113.011 Scalpel for Percutaneous Aiming Arm Instruments



03.113.012 Drill Sleeve Ø 2.5 mm, for neutral position, percutaneous



03.113.013 Drill Sleeve Ø 2.5 mm, for compression position, percutaneous



---

03.113.014 Handle for Drill Sleeves with thread



---

03.113.015 Pull Reduction Device for Outer Sleeve, for LCP Percutaneous Aiming Instruments 3.5



---

03.113.016 Nut for Pull Reduction Device (This Spare part is integrated in 03.113.015)



---

03.113.020 Locking Drill Sleeve Ø 2.8 mm, percutaneous



---

03.113.022 Centering Sleeve, percutaneous, for Kirschner Wire Ø 1.6 mm



---

03.113.028      Depth Gauge for Percutaneous Aiming  
Arm Instruments



---

321.160      Combination Wrench Ø 11.0 mm



---

314.160      Allen Key, small, Ø 2.5 mm, angled



# Sets

---

## Plates

---

01.127.001 VA-LCP Proximal Tibial Plates 3.5 (Stainless Steel), in Modular Tray, Vario Case System

---

68.127.001 Vario Case for VA-LCP Proximal Tibial Plates 3.5, size 1/1, including 68.127.002 and 68.127.003

---

68.127.002 Modular Tray for VA-LCP Proximal Tibial Plates 3.5, Small Bend, size 1/1, without Contents, Vario Case System

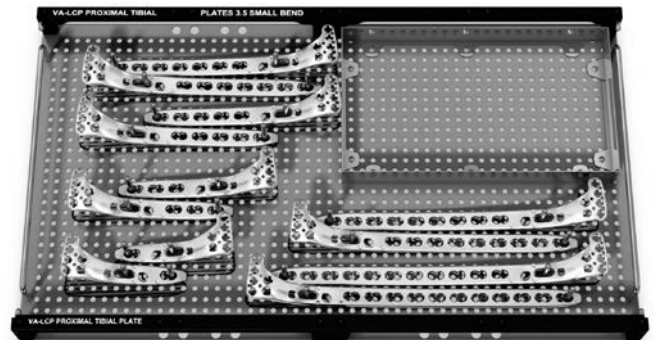

---

68.127.003 Modular Tray for VA-LCP Proximal Tibial Plates 3.5, Large Bend, size 1/1, without Contents, Vario Case System

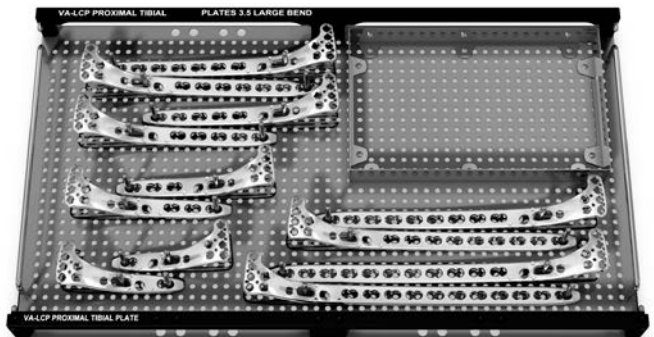

---

**VA Instruments**

---

01.127.003 VA Instruments and Long Screw Insertion Instruments 3.5, in Modular Tray, Vario Case System

---

68.127.004 Vario Case for VA Instruments and Long Screw Insertion Instruments, size 1/1, including 68.127.005 and 68.127.006

---

68.127.005 Modular Tray for VA Instruments 3.5, size 1/2, without Contents, Vario Case System



---

68.127.006 Modular Tray for Long Screw Insertion Instruments 3.5, size 1/2, without Contents, Vario Case System

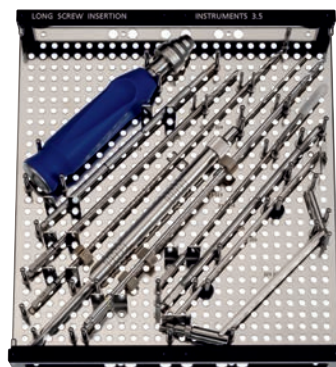

---

## Aiming Arm Instruments

---

01.127.004 Aiming Arm Instruments for VA-LCP Proximal Tibial Plates 3.5, in Modular Tray, Vario Case System

---

68.127.007 Modular Tray for Aiming Arm Instruments, for VA-LCP Proximal Tibial Plates 3.5, size 1/1, without Contents

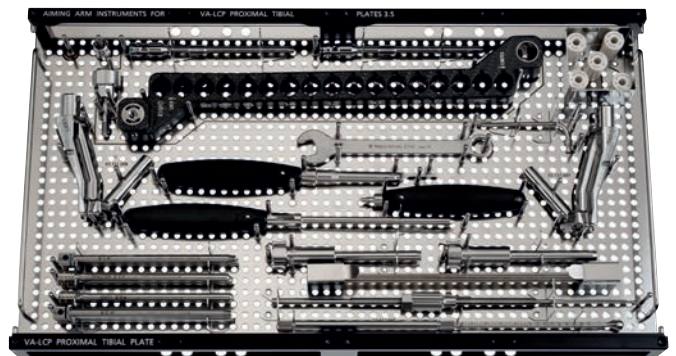

---

## Screws

---

68.122.054 Modular Screw Rack, with Drawer, Measuring Block and Lid, length 200 mm, height 115 mm, size 1/2, without Contents, Vario Case System

---

68.127.008 Modular Tray, for Modular Screw Rack, for Screws Ø 3.5 mm, with Long Measuring Scale, size 1/3, without Contents, Vario Case System



# Bibliography

---

Hem S. et al. Preliminary results of a new injectable and drillable bone void filler in the treatment of tibia plateau fractures: A first case review, *Synthes* 2009.

Müller ME, M Allgöwer, R Schneider, H Willenegger. *Manual of Internal Fixation*. 3rd ed. Berlin Heidelberg New York: Springer. 1991.

Rüedi TP, RE Buckley, CG Moran. *AO Principles of Fracture Management*. 2nd ed. Stuttgart, New York: Thieme. 2007.

Ryf C. et al. A new injectable brushite cement: First Results in Distal Radius and Proximal Tibia Fractures, *Eur J Trauma Emerg Surg* 2009, 35: 389-96.

# MRI Information

---

## **Torque, Displacement and Image Artifacts according to ASTM F 2213-06, ASTM F 2052-14 and ASTM F2119-07**

Non-clinical testing of worst case scenario in a 3 T MRI system did not reveal any relevant torque or displacement of the construct for an experimentally measured local spatial gradient of the magnetic field of 3.69 T/m. The largest image artifact extended approximately 169 mm from the construct when scanned using the Gradient Echo (GE). Testing was conducted on a 3 T MRI system.

## **Radio-Frequency-(RF-)induced heating according to ASTM F2182-11a**

Non-clinical electromagnetic and thermal testing of worst case scenario lead to peak temperature rise of 9.5 °C with an average temperature rise of 6.6 °C (1.5 T) and a peak temperature rise of 5.9 °C (3 T) under MRI Conditions using RF Coils [whole body averaged specific absorption rate (SAR) of 2 W/kg for 6 minutes (1.5 T) and for 15 minutes (3 T)].

**Precautions:** The above mentioned test relies on non-clinical testing. The actual temperature rise in the patient will depend on a variety of factors beyond the SAR and time of RF application. Thus, it is recommended to pay particular attention to the following points:

- It is recommended to thoroughly monitor patients undergoing MR scanning for perceived temperature and/or pain sensations.
- Patients with impaired thermo regulation or temperature sensation should be excluded from MR scanning procedures.
- Generally it is recommended to use a MR system with low field strength in the presence of conductive implants. The employed specific absorption rate (SAR) should be reduced as far as possible.
- Using the ventilation system may further contribute to reduce temperature increase in the body.

